

Thermal Desorption Tubes, Accessories & Spares

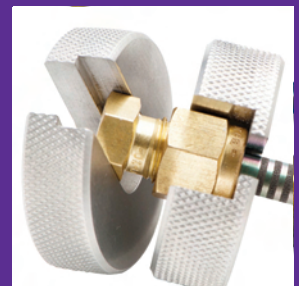

Series2
UNITY

World-leading products for thermal desorption



Contents

Sorbent tubes and cold traps	3	Headspace–thermal desorption	39
Stainless steel tubes	4	Bio-VOC breath sampler	40
Inert-coated stainless steel tubes	6	VOC-Mole soil probe	40
Glass tubes	7	Direct desorption	41
SafeLok tubes	8	Thermal analysis and evolved gas collection	42
DAAMS tubes	9	Custom solutions	42
Sorbent tube labelling	10		
TubeTAG – Error-free sorbent tube information handling	11	Starter kits	43
TubeTAG accessories	12	Markes’ general TD starter kits	44
Standard tubes packed to your requirements	13	Application-specific starter kits	44
Additional options for sorbent tubes	13	Product-specific starter kits	47
Cold traps (focusing traps)	14		
Tube accessories	15	Instrument spares	49
Caps	16	TD-100	50
Gauzes and springs	17	UNITY 2	51
Tools	17	ULTRA 2	53
Tube connection unions	18	Air Server and Canister Interface Accessory (CIA) systems	54
		CIA <i>Advantage</i>	55
Tube-based air sampling	19	TT24-7	56
ACTI-VOC low-flow pump	20	UNITY 1	58
Easy-VOC grab-sampler	20	Routine maintenance kits	60
MTS-32 multiple tube sampler	21		
Diffusive (passive) sampling	22	Laboratory accessories	61
		Pneumatic control accessories	62
Canister-based air sampling	23	Helium leak detector	62
Air-monitoring canisters	24	Flowmeter	62
Canister rack	25	Gas purifiers	63
Canister cleaning system	25	Syringes	64
		Capillary column cutting tool	64
Calibration and standards	27	Fused silica column connectors	64
Calibration Solution Loading Rig	28	Copper tubing and unions	64
Liquid-phase external calibration tubes	28		
Check-standard tubes	29	Sorbents	65
Certified reference standard (CRS) tubes	31	Porous polymers	66
Internal standards	32	Graphitised carbon blacks	66
Gas standards for external calibration of environmental methods	32	Carbonised molecular sieves	67
		Zeolite molecular sieves	67
		Other sorbents	67
Sampling accessories	35	Applications Guides	69
Micro-Chamber/Thermal Extractor	36	List of part numbers	70
SPE-tD cartridges	38	Index	72
TC-20 multi-tube conditioner and dry-purge unit	39		

Ordering information

Ordering from Markes couldn't be simpler, whether by phone, fax, email or online. Payment is accepted by credit card (Mastercard or Visa) on account. If you need help with your order, simply contact one of our highly experienced chemists or customer service agents at any of Markes' main sales locations:

- **Markes International Ltd**
Gwaun Elai Medi-Science Campus
Llantrisant
RCT, CF72 8XL
UK

Tel.: +44 (0)1443 230935

Fax: +44 (0)1443 231531

- **Markes International, Inc.**
11126 Kenwood Road
Cincinnati
Ohio 45242
USA

Tel.: 866-483-5684 (toll-free)

Fax: 513-745-0741

- **Markes International GmbH**
Schleussnerstrasse 42
D-63263 Neu-Isenburg
Frankfurt
Germany

Tel.: +49 (0)6102 8825569

Fax: +49 (0)6102 8825583

Web: www.markes.com

Email: enquiries@markes.com

You can also place orders with any of our global distributors: www.markes.com/Global-Distributors.aspx

Quality-assured accessories and consumables from the TD experts

When it comes to accessories and consumables for thermal desorption, we offer our customers nothing but the best:

- Application expertise that is second-to-none.
- Fast delivery and excellent customer service.
- The widest range of sorbent sampling tubes – whatever your TD application, we have the optimum solution.
- World-leading, patented technologies for thermal desorption.
- Stringent quality control of our manufacturing procedures.
- ISO 9001 accreditation.
- Worldwide distributor and user base.
- Custom service – if you want something special, we can do it.

And most importantly... a 100% quality guarantee.

If you're not satisfied with the products we supply, we will provide replacements or give you your money back, whichever you prefer.



Contact Markes today for fast and friendly advice on any aspect of thermal desorption.

Sorbent tubes and cold traps

Unmatched product range, with expert advice from the world's leading TD supplier

Product highlights

- Unrivalled range of tube types and sorbent options
- Quality assured – each tube individually checked
- Sophisticated tube labels as standard
- Innovative TubeTAG™ system for ultimate tube traceability
- Fast delivery and competitive prices
- Quality-assured cold traps
- Expert technical advice and applications support



Contact Markes International for expert advice

Email

enquiries@markes.com

Web

www.markes.com

Telephone

UK: +44 (0)1443 230935

USA: 866-483-5684 (toll-free)

Germany: +49 (0)6102 8825569

Stainless steel tubes



Markes International's industry-standard stainless steel tubes are made from the highest-specification materials, and are suitable for the majority of VOC air monitoring applications across a wide range of compound types and atmospheric concentrations. They comply with official standard methods such as US EPA Method TO-17 and EN ISO 16017.

All Markes' industry-standard tubes are 3½" (89 mm) long, with ¼" (6.4 mm) o.d. and 5 mm i.d. They are manufactured to precise tolerances under ISO 9001, and we guarantee their compatibility with any TD system that supports industry-standard tubes.

Your quick guide to Markes International's most popular stainless steel tubes

Description (all in packs of 10)	Part number	
	Unconditioned, without caps	Conditioned and capped
Air toxics tube	C2-AXXX-5270	C2-AAXX-5270
Universal tube	C3-AXXX-5266	C3-AAXX-5266
Material emissions tube	C3-AXXX-5304	C3-AAXX-5304
EPA 325 tube for BTEX and butadiene, with TubeTAG	—	C1-ACAX-5009
SVOC air tube	C1-AXXX-5342	C1-AAXX-5342
Soil gas tube	C3-AXXX-5304	C3-AAXX-5304
Packed with Tenax TA	C1-AXXX-5003	C1-AAXX-5003
Packed with Tenax TA–Carbograph 1TD	C2-AXXX-5032	C2-AAXX-5032
Packed with Carbograph 2TD–Carbograph 1TD	C2-AXXX-5126	C2-AAXX-5126
Packed with Carbograph 1TD	C1-AXXX-5009	C1-AAXX-5009
Packed with Carbopack X	C1-AXXX-5020	C1-AAXX-5020
Empty	C0-AXXX-0000	—



If you don't see what you're looking for, just contact Markes International.



Tubes perfect for your application...



Diffusive (passive) sampling of fugitive emissions in accordance with US EPA Method 325: C1-ACAX-5009

Markes International offers both of the stainless steel tubes referenced in US EPA Method 325, and is happy to advise on which option would work best for you. Combination kits are also available for monitoring both volatile and less volatile target compounds.



Soil gas/vapour intrusion: C3-AAXX-5304

These stainless steel tubes, packed with the best sorbents for monitoring underground contamination and vapour intrusion, are compatible with everything from C₄ hydrocarbons to middle-distillate fuels, as well as high-humidity air streams.



Material emissions testing and indoor air monitoring: C3-AAXX-5304

These tubes comply with ISO 16000-6 recommendations for simultaneous monitoring of VVOCs, VOCs and SVOCs. They are particularly suitable for monitoring indoor air quality and for testing chemicals released by products and materials.



Inert-coated stainless steel tubes



Markes International's inert-coated stainless steel tubes are a robust alternative to glass tubes for sampling thermally labile and reactive compounds, due to the extremely thin inert coating on all surfaces, including the front sorbent-retaining gauze.

Your quick guide to Markes International's most popular inert-coated stainless steel tubes

Description (all in packs of 10)	Part number	
	Unconditioned, without caps	Conditioned and capped
Material emissions tube	C3-CXXX-5304	C3-CAXX-5304
Odour tube	C2-CXXX-5314	C2-CAXX-5314
SVOC air tube	C1-CXXX-5342	C1-CAXX-5342
Soil gas tube	C3-CXXX-5304	C3-CAXX-5304
Packed with Tenax TA	C1-CXXX-5003	C1-CAXX-5003
Empty	C0-CXXX-0000	—

Tubes perfect for your application...



Monitoring odours: C2-CAXX-5314

These inert-coated stainless steel tubes are packed with a carefully optimised combination of weak and strong inert sorbents, making them perfect for profiling a wide range of compounds including reactive sulfur species.



If you don't see what you're looking for, just contact Markes International.

Glass tubes



Markes' glass tubes have a restriction rather than a fused glass frit, leading to better recovery of reactive and higher-boiling species.

Markes International's high-quality glass tubes are completely inert, making them ideal for sampling reactive species. The clarity of the glass makes it easy to check the status of the sorbent, while also making them perfect for direct desorption of small samples.

As well as the standard 3½" tubes listed below, Markes also supplies glass DAAMS and Mini tubes – see page 9.



Your quick guide to Markes International's most popular glass tubes

Description (all in packs of 10)	Part number	
	Unconditioned, without caps	Conditioned and capped
Air toxics tube	C2-BXXX-5259	C2-BAXX-5259
Universal tube	C3-BXXX-5267	C3-BAXX-5267
Packed with Tenax TA	C1-BXXX-5039	C1-BAXX-5039
Packed with Tenax TA–Carbograph 5TD	C2-BXXX-5201	C2-BAXX-5201
Empty, with restriction at 30 mm	C0-NXXX-0000	—

Tubes perfect for your application...



Monitoring 'air toxics': C2-BAXX-5259

Packed with medium and strong sorbents, these glass tubes trap polar and non-polar 'air toxics' ranging from propene to hexachlorobutadiene, with minimal water retention. Used with Markes' UNITY or TD-100 systems, they provide optimum performance and full compliance with US EPA Method TO-17.



Direct desorption of materials: C0-NXXX-0000

These glass tubes, with a restriction at 30 mm, guarantee correct positioning of material samples for direct desorption, as well as allowing easy inspection of samples before and after analysis.

SafeLok™ tubes

Markes International's SafeLok tubes provide unrivalled protection for trace and toxic samples, while complying fully with standard methods for pumped sampling.

With a diffusion-locking insert at each end, SafeLok tubes ensure sample integrity throughout storage, transport and analysis. They are available in both regular and inert-coated stainless steel, and contain the same amount of sorbent as standard tubes.



Markes' patented SafeLok tubes incorporate a diffusion-locking insert at each end, preventing sample loss or contamination.

Your quick guide to Markes International's most popular SafeLok tubes

Description (all in packs of 10)	Part number	
	Unconditioned, without caps	Conditioned and capped
Stainless steel, packed with Tenax TA	C1-DXXX-5003	C1-DAXX-5003
Stainless steel, universal	C1-DXXX-5266	C1-DAXX-5266
Inert-coated stainless steel, packed with Tenax TA	C1-EXXX-5003	C1-EAXX-5003
Inert-coated stainless steel, universal	C3-EXXX-5266	C3-EAXX-5266
Inert-coated stainless steel, packed with Tenax TA–SulfiCarb	C1-EXXX-5312	C1-EAXX-5312

Tubes perfect for your application...

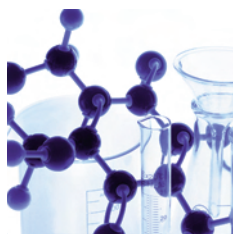

Monitoring unknown atmospheres: C3-DAXX-5266

An optimised combination of weak, medium and strong sorbents allows near-universal screening of VOCs and SVOCs in uncharacterised indoor and outdoor environments, with minimal water retention. SafeLok technology makes these tubes uniquely resistant to chemical losses or contamination.



DAAMS tubes

DAAMS tubes are packed by Markes International's experts to ensure optimum recovery of challenging and toxic analytes such as chemical agents, making them ideal for chemical defence and counter-terrorism applications.

These tubes have dimensions of 4½" (114 mm) × 6 mm o.d., with ~4 mm i.d., and are compatible with Markes' (ULTRA-)UNITY-X thermal desorber and other third-party TD platforms.



Description (all in packs of 10)	Part number
DAAMS tube, 4½" × 6 mm, unconditioned, without caps, empty	C0-LXXX-0000
DAAMS tube, 4½" × 6 mm, unconditioned, without caps, packed with Tenax TA (suitable for most of the 'G' agents, HD, VX and 'Russian VX', amongst others)	C1-LXXX-7001
DAAMS tube, 4½" × 6 mm, unconditioned, without caps, packed with HayeSep D (suitable for the 'G' analogue of VX)	C1-LXXX-7003



If you don't see what you're looking for, just contact Markes International.



Sorbent tube labelling

Standard features

All Markes International's tubes are permanently labelled with a **unique ID number, in clear alphanumeric and barcode formats**, to help you keep track of samples and tube stock. The barcodes reduce errors and minimise time-consuming manual data entry. See below for Markes' range of recommended barcode readers.

Each tube also features a **sampling arrow** indicating the direction of the air/gas sampling flow to aid field monitoring.

Special labelling options

You can specify up to 10 additional **alphanumeric characters** to be etched on Markes International's stainless steel tubes – for example, to identify the sorbent, maximum temperature or company name. Just include clear details of your requirements with your order.

Stainless steel tubes can also be etched with up to five **permanent black bands**, for rapid visual identification of sorbent type or project ID. Just send us your banding requirements with your order, or contact us with any questions.

Barcode reader for sorbent tubes

Markes International supplies a barcode reader for accurate and reliable reading of barcodes on Markes' metal and glass sorbent tubes.

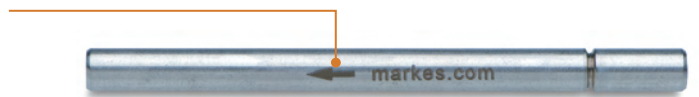

 For more information on any of Markes International's sorbent tube labelling options, just contact a technical specialist for expert advice.

Description	Part number
Corded barcode reader (for at-PC use; available USB port required)	C-BCR

TubeTAG™ – Error-free sorbent tube information handling

Offering total peace-of-mind, Markes International's patented TubeTAG technology allows you to track tube history throughout the lifetime of a tube, and log sample information.

Using robust radio-frequency identification (RFID) tags that clip securely onto stainless steel or glass tubes, TubeTAG eliminates transcription errors, optimising control of the chain of custody throughout field monitoring and laboratory analysis. It is recommended by key standard methods such as US EPA Method 325.

TubeTAG is compatible with Markes' entire range of TD systems, and TubeTAGs are easily fitted to your existing tube stock.



↓ For more information on TubeTAG, refer to the separate brochure and Application Note 082.

i For details of Markes International's cost-effective TubeTAG starter kit, see page 47.



To request sorbent tubes with TubeTAG RFID tags already attached, just specify "TubeTAG" when placing your tube order.

TAGSCRIBE™

Markes International's portable Windows®-based laptop- or tablet-controlled TAGSCRIBE is a convenient alternative to using a tag-ready TD autosampler to enter information onto tags, whether in the field or laboratory.



The versatile TubeTAG software interface allows you to enter a wide range of tube and sample information, including the sorbent details, project name, monitoring location, and sampling parameters.

Description	Part number
TAGSCRIBE read/write device for all TubeTAGs	C-SCRIBE



TubeTAG accessories

Packs of tags for fitting to sorbent tubes

For attaching to existing sorbent tubes, whether stainless steel or glass.



Description	Part number
TubeTAG for stainless steel tubes, pk 10	C-TAG10
TubeTAG for stainless steel tubes, pk 100	C-TAG100
TubeTAG for glass tubes, pk 10	C-TAGG10
TubeTAG for glass tubes, pk 100	C-TAGG100

Tools for TubeTAG

Special tools for fixing and removing tags, and for fitting TubeTAG-compatible storage caps.



Description	Part number
TubeTAG fixing/removal tool for stainless steel tubes	C-TAGTL
TubeTAG fixing/removal tool for glass tubes	C-TAGKY
TAGLok tool for tightening/removing standard and TAG-ready 1/4" storage caps	C-TAGLOK

TubeTAG-compatible storage caps

These long-term storage caps ensure that tagged tubes are securely sealed.



Description	Part number
Tag-ready 1/4" brass long-term storage caps for industry-standard stainless steel tubes	
Cap, brass, 1/4" & PTFE ferrule, tag-ready, pk 10, for 1/4" metal tubes	C-TCF10
Cap, brass, 1/4" & PTFE ferrule, tag-ready, pk 100, for 1/4" metal tubes	C-TCF100

[Tag-ready 1/4" or 6 mm brass long-term storage caps for glass tubes](#)

Cap, brass, 1/4" & blind PTFE ferrule, tag-ready, pk 10, for 1/4" glass tubes	C-T4GCF10
Cap, brass, 1/4" & blind PTFE ferrule, tag-ready, pk 100, for 1/4" glass tubes	C-T4GCF100
Cap, brass, 6 mm & blind PTFE ferrule, tag-ready, pk 10, for 6 mm glass tubes	C-T6GCF10
Cap, brass, 6 mm & blind PTFE ferrule, tag-ready, pk 100, for 6 mm glass tubes	C-T6GCF100

[Pairs of long-term storage caps for 1/4" tagged tubes](#)

Cap, brass, 1/4" & PTFE ferrule (one standard, one tag-ready), pk 10 pairs, for 1/4" metal tubes	C-TCFP10
Cap, brass, 1/4" & PTFE ferrule (one standard, one tag-ready), pk 100 pairs, for 1/4" metal tubes	C-TCFP100



Talk to Markes International to discuss any aspect of implementing TubeTAG technology in your laboratory.

Standard tubes packed to your requirements

Many TD users take advantage of Markes International's expertise when selecting the best sorbent tube for their application, so just contact us if you'd like us to pack a customised tube that precisely meets your requirements.

Additional options for sorbent tubes

As the world's leading thermal desorption company, Markes International understands the demands of difficult applications, and is uniquely well-placed to provide the extra help you may need:

- TD-GC-MS blank profiling for conditioned tubes.
- Labelling or barcoding of existing tube stock.
- Custom labelling of glass tubes.
- Non-standard tube dimensions.
- Alternative sorbent mesh sizes, bed lengths, or packing mixes.
- Tube unpacking and repacking.
- Conditioning of existing tubes.

...or anything else! Markes' specialists are always happy to discuss your requirements.



For more information on Markes International's custom solutions, whether for sampling accessories or sorbent tubes, speak to a technical specialist.



Cold traps (focusing traps)



Recommended cold traps for UNITY 2 and TD-100 instruments

Description	Part number
Cold trap, high-boilers, n-C ₆ to n-C ₄₀	U-T1HBL-2S
Cold trap, general-purpose hydrophobic, n-C _{4/5} to n-C _{30/32}	U-T2GPH-2S
Cold trap, sulfur/labile	U-T6SUL-2S
Cold trap, empty	U-T7EMP-2S
Cold trap, custom-packed	U-T8CUS-2S
Cold trap, chemical warfare agents	U-T10CW-2S
Cold trap, general-purpose carbon, n-C _{4/5} to n-C _{30/32}	U-T11GPC-2S
Cold trap, material emissions, n-C ₄ to n-C ₃₂	U-T12ME-2S
Cold trap, TO-15/TO-17 air toxics, C _{2/3} to n-C _{30/32}	U-T15ATA-2S
Cold trap, greenhouse gases, C ₂ to n-C ₁₄	U-T16GHG-2S
Cold trap, ozone precursors	U-T17O3P-2S
Cold trap, 325	U-T18325-2S

Recommended cold traps for UNITY 1 instruments

Description	Part number
Cold trap, high-boilers, n-C ₆ to n-C ₄₀	U-T1HBL
Cold trap, general-purpose hydrophobic, n-C _{4/5} to n-C _{30/32}	U-T2GPH
Cold trap, sulfur/labile	U-T6SUL
Cold trap, empty	U-T7EMP
Cold trap, custom-packed	U-T8CUS
Cold trap, chemical warfare agents	U-T10CW
Cold trap, general-purpose carbon, n-C _{4/5} to n-C _{30/32}	U-T11GPC
Cold trap, material emissions, n-C ₄ to n-C ₃₂	U-T12ME
Cold trap, TO-15/TO-17 air toxics, C _{2/3} to n-C _{30/32}	U-T15ATA
Cold trap, greenhouse gases, C ₂ to n-C ₁₄	U-T16GHG
Cold trap, ozone precursors	U-T17O3P

Recommended cold traps for TT24-7 Series 1 and Series 2 instruments

Note: Two traps are required for each system.

Description	Part number
Cold trap, TT24-7, for CWAs (in particular VX)	T-1VX
Cold trap, TT24-7, for CWAs (in particular HD)	T-2HD
Cold trap, TT24-7, for CWAs (in particular the GB/GE analog of VX)	T-3GBGE
Cold trap, TT24-7, for air toxics	T-4ATX
Cold trap, TT24-7, empty for packing	T-6EMP
Cold trap, TT24-7, custom-packed	T-7CUS
Cold trap, TT24-7, for material emissions	T-8MAT
Cold trap, TT24-7, general-purpose carbon black	T-9GPC
Cold trap, TT24-7, for ozone precursors	T-11OP
Cold trap extraction tool for TT24-7	SERTTD-5032



To purchase any of Markes International's cold traps, or enquire about availability of previously listed traps, simply contact Markes' technical specialists.

Tube accessories

Everyday tools for enhanced tube sampling

Product highlights

- Specialist accessories designed to enhance data confidence and make your job easier
- CapLok™ tool to simplify tube capping and uncapping
- The only storage caps independently validated to maintain sample integrity for over 2 years
- Patented analytical caps to ensure sample integrity and stability on Markes' TD autosamplers
- Convenient tube unions



**Contact Markes
International for
expert advice**

Email

enquiries@markes.com

Web

www.markes.com

Telephone

UK: +44 (0)1443 230935

USA: 866-483-5684 (toll-free)

Germany: +49 (0)6102 8825569

Caps

Long-term storage caps

Markes International's precision-engineered long-term storage caps meet stringent cleanliness specifications and tight manufacturing tolerances. They are recommended by international standard methods and are independently validated for long-term sample storage (up to 27 months).

They are available in brass or aluminium, and should be used with a combined PTFE ferrule (1/4" or 6 mm i.d. as required).



Description	Part number
Standard 1/4" brass and aluminium long-term storage caps for industry-standard tubes (stainless steel or glass)	
Cap, storage, brass, 1/4" & PTFE ferrule, pk 10	C-CF010
Cap, storage, brass, 1/4" & PTFE ferrule, pk 20	C-CF020
Cap, storage, brass, 1/4" & PTFE ferrule, pk 100	C-CF100
Cap, storage, brass, 1/4" & PTFE ferrule, pk 200	C-CF200
Cap, storage, aluminium, 1/4" & PTFE ferrule, pk 20	C-CFA20
Cap, storage, aluminium, 1/4" & PTFE ferrule, pk 200	C-CFA200
Ferrule, 1/4", combined PTFE, pk 20	C-FP020
Ferrule, 1/4", combined PTFE, pk 200	C-FP200

[6 mm brass long-term storage caps for 6 mm stainless steel tubes or glass tubes with 6 mm o.d. ends²](#)

Cap, storage, brass, 6 mm & PTFE ferrule, pk 10	C-CF010-XZ
Cap, storage, brass, 6 mm & PTFE ferrule, pk 20	C-CF020-XZ
Cap, storage, brass, 6 mm & PTFE ferrule, pk 100	C-CF100-XZ
Cap, storage, brass, 6 mm & PTFE ferrule, pk 200	C-CF200-XZ
Ferrule, 6 mm, combined PTFE, pk 20	C-FP020-XZ
Ferrule, 6 mm, combined PTFE, pk 200	C-FP200-XZ

 **For advice on tube capping and storage, see Application Note 019.**

DiffLok™ caps

The patented diffusion-locking technology used in DiffLok caps preserves sample integrity by preventing both analyte loss and artefact ingress, while still allowing analytes to be released into the TD instrument when pressure is applied.

Unique to Markes International, DiffLok caps simply push on to the ends of tubes and guarantee reproducible results during analysis on Markes' ULTRA and TD-100 autosamplers.



DiffLok caps are available for 1/4" and 6 mm o.d. tubes and are available in stainless and inert-coated steel.

Description	Part number
Cap, DiffLok, stainless steel, 1/4", pk 10	C-DL010
Cap, DiffLok, stainless steel, 1/4", pk 100	C-DL100
Cap, DiffLok, inert, 1/4", pk 10	C-DLS10
Cap, DiffLok, inert, 1/4", pk 100	C-DL1S0
Cap, DiffLok (one stainless steel, one inert), 1/4", pk 10 pairs	C-DLP10
Cap, DiffLok (one stainless steel, one inert), 1/4", pk 100 pairs	C-DL1P0

Short-term storage caps

Aluminium push-on caps with O-ring seals are convenient for short-term storage of cleaned or sampled 1/4" tubes.



Description	Part number
Cap, push-on, aluminium, 1/4", pk 20	C-AC020
Cap, push-on, aluminium, 1/4", pk 200	C-AC200
O-Ring, low-emission, pk 10 (replacements for 6 mm DiffLok caps)	U-COV45
O-Ring, low-emission, pk 100 (replacements for 6 mm DiffLok caps)	U-COV450

Gauzes and springs

Sorbent-retaining gauzes

Markes International's sorbent-retaining gauzes are manufactured from high-quality regular or inert-coated stainless steel for accurate sorbent positioning and robust separation of multiple sorbents above 80 mesh particle size.

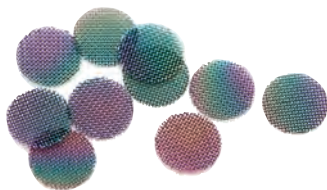

Description	Part number
Sorbent-retaining gauze, pk 20	C-GZ020
Sorbent-retaining gauze, pk 200	C-GZ200
Sorbent-retaining gauze, pk 2000	C-GZ2000
Sorbent-retaining gauze, inert, pk 10	C-GZI10
Sorbent-retaining gauze, inert, pk 100	C-GZI100

Gauze-retaining springs

Inserted and removed using the TubeMate tool, gauze-retaining springs ensure the rear sorbent-retaining gauze is correctly positioned on top of the sorbent bed in metal tubes.



Description	Part number
Gauze-retaining spring, pk 10	C-SP010
Gauze-retaining spring, pk 100	C-SP100

Torsion springs for glass tubes

Used in glass tubes, torsion springs ensure that the rear plug of quartz wool remains positioned correctly on top of the sorbent bed. They are also useful for securing material samples in the central heated zone of a tube during direct desorption.



Description	Part number
Spring, torsion, for 4 mm i.d. glass tubes, pk 10	C-GTSP10

Tools

CapLok™

Designed by scientists at INERIS in France, the CapLok tool simplifies tube capping and uncapping procedures, and minimises the risk of sample loss through incorrect capping, or tube damage through over-tightening.



Description	Part number
CapLok tool	C-CPLOK
CapLok tool, pk 10	C-10LOK

↓ For more information on using the CapLok tool, see Application Note 019.

i For details of TAGLok (an equivalent tool for tag-adapted storage caps), see page 12.

TubeMate™

TubeMate makes it easy to insert (and remove) gauze-retaining springs in metal tubes, and can also be used to position the rear sorbent-retaining gauze on the sorbent surface.



Description	Part number
TubeMate tool	C-TBMTE



To order any of these accessories, simply telephone or send an email.

Tube connection unions

Stainless steel unions fitted with one-piece PTFE ferrules make it easy to connect sorbent tubes in series, when necessary.

Tubes connected in this way are useful for monitoring breakthrough, or when collecting samples on sorbent combinations that cannot be packed into a single tube.



Description	Part number
Unions, 1/4"-1/4", stainless steel & 1/4" PTFE ferrules, pk 10	C-UNS10
Unions, 1/4"-1/4", stainless steel & 1/4" PTFE ferrules, pk 100	C-UNS100



Just contact Markes International if you have any questions on tube accessories.



Tube-based air sampling

Versatile accessories for pumped and diffusive air sampling using sorbent tubes

Product highlights

- ACTI-VOC™ – personal monitoring pump specifically optimised for thermal desorption
- Easy-VOC™ – quick grab-sampling for stack gas and industrial air
- Portable sequential sampling with the MTS-32™
- Precisely manufactured diffusion caps for accurate diffusive sampling
- New 325 Field Station™ for method-compliant refinery fenceline monitoring



**Contact Markes
International for
expert advice**

Email

enquiries@markes.com

Web

www.markes.com

Telephone

UK: +44 (0)1443 230935

USA: 866-483-5684 (toll-free)

Germany: +49 (0)6102 8825569

ACTI-VOC™ low-flow pump

ACTI-VOC is the only personal monitoring pump on the market that is optimised specifically for TD tubes. Being lightweight, compact and intrinsically safe, ACTI-VOC is ideal for personal, workplace and indoor air monitoring.

In addition, because it automatically compensates for sorbent packing density, ACTI-VOC delivers the same sampling flow (20–200 mL/min), irrespective of sorbent type or back-pressure, so minimising calibration frequency.

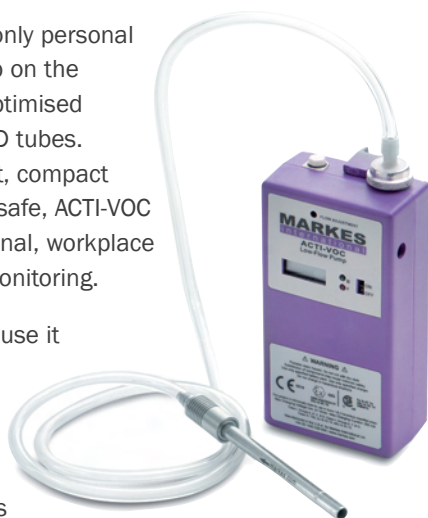

Description	Part number
ACTI-VOC low-flow pump kit	C-LFP-01
Spare ACTI-VOC filter assembly	SERZ-1076
Spare ACTI-VOC bag sampling accessory	SERZ-1070
Spare ACTI-VOC charger	SERLFP-5002
Spare ACTI-VOC tube adaptor assembly	SERZ-1097
Spare ACTI-VOC back-pressure adaptor	SERLFP-5003

↓ For more information on ACTI-VOC and Easy-VOC, download the respective brochures.

Easy-VOC™ grab-sampler

Markes International's manually-operated Easy-VOC allows simple and rapid 'grab-sampling' of precise volumes of air/gas directly onto sorbent tubes. With typical sampling volumes of 50–200 mL, key applications include industrial or workplace air monitoring.

Easy-VOC is also hassle-free, because it allows accurate sampling of small air volumes without batteries or electrical power, and with minimal risk of analyte breakthrough.



Description	Part number
Easy-VOC pump (plus CapLock tool and carry-case)	C-EZVOCPO
Easy-VOC starter kit	C-EZVOCKT
Easy-VOC accessory pack	C-EZVOCAK

i For details of Markes International's cost-effective Easy-VOC starter kit, see page 47.



 Contact Markes International to purchase these products, and for advice about optimum sampling flows for different applications.

MTS-32™ multiple tube sampler

Markes International's MTS-32 is a compact, portable sampler perfect for unattended monitoring of ambient, indoor or workplace atmospheres over extended periods.

Air is continually drawn into the case and pumped sequentially through up to 32 standard (3½") sorbent tubes. The flow rate is the same regardless of any impedance variation, ensuring consistent sampling across all 32 tubes.



For maximum confidence in results, all tubes should be sealed using Markes' DiffLok caps (see page 16), to prevent diffusive ingress or loss of volatiles.

A wide range of flow rates and sampling times, together with mains or battery-powered operation, make the MTS-32 suitable for a wide range of air monitoring applications.

Description	Part number
MTS-32 multiple tube sampler <i>Also requires constant-flow pump (e.g. ACTI-VOC low-flow pump), 12 V battery and charger, or mains power supply</i>	MTS-32
Power supply accessory for MTS-32	MTS-5011
12 V Battery assembly for MTS-32	MTS-5009
Mains charger for 12 V battery of MTS-32	MTS-5010
Cable assembly for connecting MTS-32 to external 12 V battery <i>Required if 12 V battery is not supplied by Markes</i>	MTS-5013
Spare ACTI-VOC filter assembly	SERZ-1076
Spare ACTI-VOC bag sampling accessory	SERZ-1070
Spare ACTI-VOC charger	SERLFP-5002
Spare ACTI-VOC tube adaptor assembly	SERZ-1097
Spare ACTI-VOC back-pressure adaptor	SERLFP-5003

i Markes International's specialists recommend the ACTI-VOC pump for use with the MTS-32.

↓ For more information on MTS-32, download the separate brochure.



Contact Markes International's product specialists to purchase the MTS-32, or to discuss product options.



Diffusive (passive) sampling

Diffusive sampling using sorbent tubes is a convenient, quantitative and inexpensive air monitoring option for applications ranging from personal exposure studies to routine monitoring of industrial and urban air.

Diffusion caps

Markes International's robust diffusion caps are made of anodised aluminium and fit on to the end of standard 3½" metal tubes (see pages 4–6). Stainless steel caps are also available for more corrosive atmospheres. If enhanced traceability is required, Markes can also etch each diffusion cap with a unique serial number.



Description	Part number
Caps, diffusion, axial, aluminium, pk 10	C-DF010
Caps, diffusion, axial, aluminium, pk 100	C-DF100
Caps, diffusion, axial, aluminium, etched with serial number, pk 10	C-DF010E
Caps, diffusion, axial, aluminium, etched with serial number, pk 100	C-DF100E
Caps, diffusion, axial, stainless steel, pk 20	C-DFS20

Penclips

Penclips attach to the groove on 3½" metal tubes, so that they can be easily fastened to a lapel or pocket for personal monitoring.



Description	Part number
Penclip, pk 10	C-CL010
Penclip, pk 100	C-CL100

325 Field Station™

This is a sturdy, weatherproof shelter for extended outdoor sorbent tube sampling, fully compliant with standard methods such as the forthcoming US EPA Method 325 for diffusive sampling at refinery perimeters.

Supplied with fittings for installation onto posts or fencing, the 325 Field Station can accommodate up to five diffusive tubes for sampling of benzene and other hazardous VOCs, and is fully compatible with Markes' TubeTAG system (see page 11) for convenient electronic logging of sample information in the field.

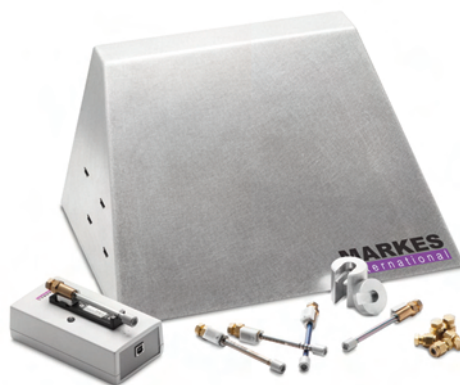

Description	Part number
325 Field Station	C-325FS

- For a list of uptake rates onto diffusive samplers, download Application Note 001; for a detailed guide to diffusive monitoring, download Application Notes 008 and 010.**
- For details of Markes International's cost-effective Diffusive monitoring starter kit, see page 45.**

For more information on analytical equipment and labour-saving accessories enabling you to comply with key diffusive sampling methods, please talk to Markes International's specialists.

Canister-based air sampling

Simple sampling for very volatile airborne organics

Product highlights

- Canisters for US EPA Methods TO-14 and TO-15
- Handy rack for convenient canister storage
- Canister cleaner for reliably accurate sampling



**Contact Markes
International for
expert advice**

Email
enquiries@markes.com

Web
www.markes.com

Telephone
UK: +44 (0)1443 230935
USA: 866-483-5684 (toll-free)
Germany: +49 (0)6102 8825569

Air-monitoring canisters

Canisters complement sorbent tubes, by allowing quantitative sampling of the most volatile air pollutants such as C₂ hydrocarbons and freons.

The TO-Can and SilcoCan are available in 1 L and 6 L sizes, and are pre-fitted with a ¼" three-port valve and a vacuum pressure gauge, reading from -30 to 122 inHg (-15 to 60 psi). All canisters are shipped clean and pressurised with contaminant-free nitrogen.



TO-Can® canisters

Optimised for US EPA Methods TO-14/TO-15 and ASTM D5466, these electropolished canisters contain high-quality metal-to-metal seals and a stainless steel diaphragm valve for the best possible performance.

Description	Part number
TO-Can with gauge and ¼" valve, 1 L	C-TOCAN1
TO-Can with gauge and ¼" valve, 6 L	C-TOCAN6

SilcoCan® canisters

Fitted with Siltek®-treated valves, these canisters offer unsurpassed inertness, even for brominated or sulfur-containing species.

Description	Part number
SilcoCan with gauge and Siltek ¼" valve, 1 L	C-SLCAN1
SilcoCan with gauge and Siltek ¼" valve, 6 L	C-SLCAN6

Miniature air sampling canisters

These mini-cans are available either electropolished or Siltek®-treated, and fitted with a Quick-Connect stem fitting, for optimised small-volume sampling of higher-concentration air or gas samples.

Description	Part number
Miniature air sampling canister (400 mL), electropolished with Quick-Connect stem fitting	C-MNCANSS
Miniature air sampling canister (400 mL), Siltek-treated with Quick-Connect stem fitting	C-MNCANSL

Canister kits and accessories

Easy to assemble in the field, Markes International's time-weighted-average (TWA) canister monitoring kits incorporate all necessary hardware for sampling over extended periods.

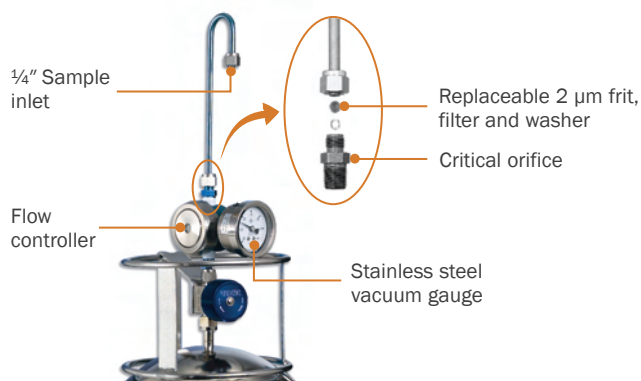

Description	Part number
TWA air sampling kit, stainless steel <i>Gives 1 h sampling from a 1 L canister or 8 h sampling from a 6 L canister</i>	C-ASK1168SS
TWA air sampling kit, Siltek-treated <i>Gives 1 h sampling from a 1 L canister or 8 h sampling from a 6 L canister</i>	C-ASK1168SL
TWA air sampling kit, electropolished, 0.5–2 mL/min (for miniature canisters only)	C-ASKMNSS
TWA air sampling kit, Siltek-treated, 0.5–2 mL/min (for miniature canisters only)	C-ASKMNSL
Replacement 2 µm frit filter for critical orifice (includes washers), stainless steel, pk 3	C-ASK2USS
Replacement 2 µm frit filter for critical orifice (includes washers), Siltek-treated, pk 3	C-ASK2UST

Canister rack

Markes International's space-saving Maxi Rack supports canisters attached to CIA *Advantage* analysers. Floor-mounted, it holds up to 15 canisters (14 samples and one internal standard).

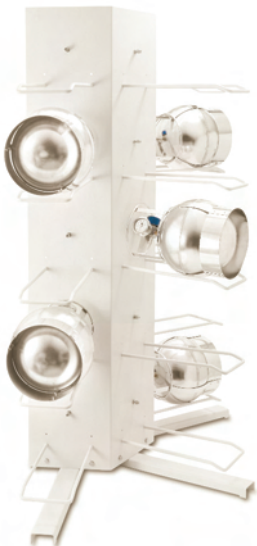

Description	Part number
Maxi Rack (1 L to 6 L canisters)	U-RACK02

i For details of Markes International's cost-effective TO-15 starter kit, see page 45.



Contact Markes International to discuss your canister application and how Markes' technologies can provide improved performance.

Canister cleaning system

Compliant with US EPA Method TO-14/TO-15, this TO-Clean canister cleaning system is easily adapted for canisters of different sizes – from twelve 6 L canisters to 48 miniature canisters – and at temperatures up to 110°C.

The system is fully automated, allowing you to start a cleaning cycle and walk away. Up to ten custom cleaning methods can be defined and loaded, while consistently high performance is ensured by the automated leak-check method.



Description	Part number
TO-Clean canister cleaning system with isothermal oven (120 V a.c.)	U-TOCLN120
TO-Clean canister cleaning system with isothermal oven (220–240 V a.c.)	U-TOCLN220
Miniature canister brackets for TO-Clean, pk 12	C-TOCLNMN
1 L brackets for TO-Clean, pk 12	C-TOCLN1L
3 L brackets for TO-Clean, pk 12	C-TOCLN3L

↓ For examples of canister sampling to monitor 'air toxics', ozone precursors and perfluorocarbons, download Application Notes 081 and 099.

Calibration and standards

Standards and accessories for reliable, quantitative thermal desorption

Product highlights

- Calibration Solution Loading Rig – the easiest way to calibrate your TD system
- Specially packed tubes for loading liquid-phase external standards
- Handy check-standards for instrument set-up and troubleshooting
- Expert-prepared certified reference standard tubes for routine quality assurance
- High-quality standards for calibration of tube and canister systems



Contact Markes International for expert advice

Email
enquiries@markes.com

Web
www.markes.com

Telephone
UK: +44 (0)1443 230935
USA: 866-483-5684 (toll-free)
Germany: +49 (0)6102 8825569

Calibration Solution Loading Rig

Markes International's Calibration Solution Loading Rig (CSLR™) has been specifically designed for loading sorbent tubes with gas- or liquid-phase standards. With an unheated injector port, it also complies with key TD standard methods such as ISO 16017, US EPA Method TO-17 and ASTM D6196.

Operation is simple – with the packed sorbent tube connected to the CSLR, the standard is injected through the septum, allowing the compounds to be swept onto the tube in a stream of carrier gas.

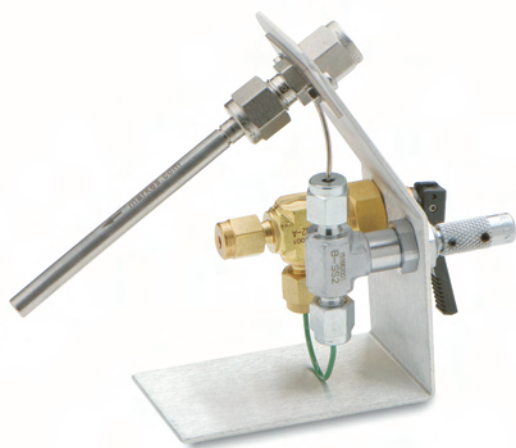

Description	Part number
Calibration Solution Loading Rig	C-CSLR
Septum, 9.5 mm (for CSLR), pk 10	C-SPTA

For more information on routine calibration of TD methods, download Application Notes 007 and 075.

Liquid-phase external calibration tubes

When it is difficult to introduce liquid standards in a stream of carrier gas, a convenient alternative is to inject them directly onto these glass sorbent tubes specially packed with a short bed of Tenax TA and quartz wool.



Description	Part number
Tube, glass, Tenax TA, 1 cm calibration, pk 10	C1-BXXX-5072
Tube, glass, Tenax TA, 1 cm calibration, conditioned and capped, pk 10	C1-BAXX-5072



Check-standard tubes

Check-standard tubes contain a range of routine and challenging analytes for troubleshooting and quality assurance. Markes International supplies two types of check-standard, both prepared on high-quality conditioned Tenax TA sorbent tubes.

Instrumentation check-standard tubes

These contain benzene, toluene, *o*-xylene, isobornyl methacrylate (IBMA) and dioctyl phthalate at a nominal concentration of 90 ng/μL for each component. A single check-standard tube is supplied with all Markes' systems.

Description	Part number
Check-standard (BTX, isobornyl methacrylate (IBMA) and dioctyl phthalate), 90 ng/μL (nominal), Tenax TA, pk 10	C-CHK10

Material emissions check-standard tubes

These enhance validation and quality control for laboratories using TD-GC methods to test chemical emissions from products and materials. The sorbent tubes are pre-loaded with n-hexane, 4-methylpentan-2-one (MIBK), toluene, n-butyl acetate, cyclohexanone, phenol, 1,2,3-trimethylbenzene, 4-phenylcyclohexene and n-hexadecane, at a nominal loading of 100 ± 10 ng per compound. The standard complies with ISO 17025 for loading tubes (also in accordance with ISO 9001).

Description	Part number
Check-standard (material emissions), 100 ng per tube (nominal), Tenax TA, pk 10	C-CHK10-ME



To order the CSLR, calibration tubes or check-standards, simply telephone or send an email.

Do you participate in a Proficiency Testing scheme for TD?

As part of our service to customers, Markes likes to make thermal desorption users aware of complementary third-party services that could be of interest and benefit. Proficiency testing (PT) schemes are a case in point.

PT schemes for thermal desorption work by providing participating laboratories with spiked tubes for analysis. The tubes are analysed by these laboratories, as part of their routine operation, and the results reported to the scheme organisers. The laboratories involved are then provided with a report showing how closely their results agree with the accepted values. Reports are confidential, as results are given by laboratory identification number, known only to the organiser and the individual laboratories.

Regular participation in a proficiency-testing scheme:

- Provides a laboratory with an important independent insight into their performance.
- Benchmarks laboratory performance against other scheme participants.
- Allows laboratories to demonstrate commitment to measurement quality to regulatory agencies, accreditation bodies and laboratory customers.

The AIR PT scheme

One of the most popular schemes for thermal desorption is the AIR PT scheme. This tests the performance of laboratories measuring exposure to hazardous chemical substances in the ambient, indoor and workplace air environments using TD methods. The scheme was established in 1988 as the Workplace Analysis Scheme for Proficiency (WASP), and currently has more than 350 laboratory participants worldwide. The WASP scheme is operated by LGC Standards (which oversees management, registration, data analysis, publishing reports, membership and distribution), working in partnership with the UK Health & Safety Laboratory (who provide technical expertise, support, and produce the dynamically loaded TD tubes and filters).



AIR PT offers the following samples for the analysis of thermal desorption tubes:

Application	Testing environment	Analytes	Loading
Ambient air	ISO 16017-1 & 2, US EPA TO-17	BTEX	15–300 ng †
Indoor air and material emissions	ISO 16000-6	Up to 13 VOCs and SVOCs	25–1000 ng
Workplace air	ISO 16017-1 & 2	BTEX	0.5–200 µg †
	ISO 16000-3	Formaldehyde	1.5–60 µg ‡

† Analytes provided together on a TD sorbent tube packed with Tenax TA. Test samples dynamically loaded from a standard atmosphere based upon procedures set out in ISO 6145-4.

‡ Glass fibre filter spiked with DNPH derivative. Note this requires HPLC, and is not compatible with TD-GC(-MS) methods.



If you are interested in AIR PT, please contact LGC Standards on +44 (0)161 762 2500 or at ptcustomerservices@lgcgroup.com.

Certified reference standard (CRS) tubes

Markes International's CRS tubes are prepared by an expert national standards laboratory following approved methodology (ISO 6145 parts 4 or 8, accredited to ISO 17025), and are certified traceable to primary standards.

Routine use of these CRS tubes complies with guidance given in international standard methods, and provides continual quality assurance of system and procedure reliability.

All CRS tubes are supplied with a shipping blank tube, and are wrapped in aluminium foil prior to shipment in air-tight boxes, offering ultimate protection. A chromatogram of the shipping blank tube is supplied, together with a certificate of standard traceability. BTX and TO-17 standard tubes are supplied with an example chromatogram and full user instructions.



To order Markes International's CRS tubes, simply telephone or send an email.

BTX standard tubes

Tenax tubes loaded with benzene, toluene and o-xylene are available either at 100 ng per component (suitable for the majority of environmental applications) or at 1 µg per component (suitable for many industrial air and material emissions applications). These standards have a certified shelf-life of 6–12 months.

Description	Part number
CRS (BTX), 100 ng, pk 10	C-BTX100-10
CRS (BTX), 1 µg, pk 10	C-BTX1UG-10

TO-17 standard tubes

A TO-17 CRS tube is available loaded with nine components typical of those found during air toxics monitoring, namely:

Benzene	1,1,1-Trichloroethane
Toluene	Methyl <i>tert</i> -butyl ether
o-Xylene	Methyl ethyl ketone
1,2,4-Trimethylbenzene	Ethyl acetate
Dichloromethane	

These standard tubes are prepared on conditioned Tenax TA tubes to the concentration you specify, and have a certified shelf-life of 6 months.

Description	Part number
CRS (TO-17), specify concentration, pk 10	C-TO17XX-10

Custom standard tubes

If you require a special combination of stable chemicals pre-loaded onto conditioned sorbent tubes, Markes International also offers a custom CRS tube service. Up to eight compounds can be specified, with the sorbent typically being Tenax TA (although others are available). Please discuss your requirements with a Markes specialist prior to ordering.

Description	Part number
CRS (custom), pk 10	C-CUST-10
CRS (custom), pk 20	C-CUST-20
CRS (custom), pk 40	C-CUST-40

Internal standards

Supplied with all Markes International’s automated TD instruments, Markes’ 1 ppm internal gas standard is perfect for complying with US EPA Methods TO-14/TO-15/TO-17 and other TD–GC–MS applications.

The cylinder (110 L, 1800 psig) is of aluminium construction (8.3 cm × 29.5 cm), is PI-marked for compliance with EU transport regulations and US DOT specification 3AL2216, and contains the following components:

- Bromochloromethane
- 1-Bromo-4-fluorobenzene
- Chlorobenzene-d₅
- 1,4-Difluorobenzene

Description	Part number
Standard, gas cylinder, TO-14A IS/tuning mix, 1 ppm	C-GS14A-1PPM
Regulator, high-purity VOC, 0–100 psi outlet	C-GSREG-100
Tubing, stainless steel, 1/8", to connect IS to ISDP	SERZ-0022



 To order Markes International’s gas standards, simply telephone or send an email.

Gas standards for external calibration of environmental methods

Markes International also offers a selection of high-quality gas standards suitable for a variety of canister- and tube-based air monitoring methods.

The standards are contained in aluminium cylinders (8.3 cm × 29.5 cm) and are PI-marked for compliance with EU transport regulations and US DOT specification 3AL2216.

Sulfur component mix – 1 ppm

Supplied in nitrogen at 1800 psig, this standard has a 6-month stability and an accuracy of ±10%. 1 mL of this standard contains approximately 2 ng of the following components:

- Carbonyl sulfide
- Dimethyl sulfide
- Ethanethiol
- Hydrogen sulfide
- Methanethiol

Description	Part number
Standard, gas cylinder, sulfur mix, 1 ppm	C-GSSUL-1PPM
Regulator, high-purity VOC, 0–100 psi outlet	C-GSREG-100

Volatiles (Japan) component mix – 1 ppm

Supplied in nitrogen at 1800 psig, this mixture of volatile organics contains some compounds that are traditionally difficult to prepare as calibration standards. 1 mL of this standard contains approximately 2–7 ng of the following components:

- Acrylonitrile
- Benzene
- Butadiene
- Chloroform
- 1,2-Dichloroethane
- Dichloromethane
- Tetrachloroethene
- Trichloroethene
- Vinyl chloride

Description	Part number
Standard, gas cylinder, volatiles (Japan mix), 1 ppm	C-GSVOL-1PPM
Regulator, high-purity VOC, 0–100 psi outlet	C-GSREG-100

TO-15 'Air toxics'/TO-17 65-component mix – 1 ppm

Supplied in nitrogen at 1800 psig. Injecting 1 mL of this mix onto a sorbent tube or cold trap introduces 2–4 ng of the following components:

Acetone	Ethanol*
Acrolein	Ethyl acetate
Benzene	Ethylbenzene
Benzyl chloride*	4-Ethyltoluene
Bromodichloromethane	Heptane
Bromoform	Hexachlorobutadiene
Bromomethane	Hexane
Butadiene	Hexan-2-one (methyl butyl ketone)
Butan-2-one (methyl ethyl ketone)	Methyl methacrylate
Carbon disulfide*	4-Methylpentan-2-one (methyl isobutyl ketone)
Carbon tetrachloride	Methyl <i>tert</i> -butyl ether
Chlorobenzene	Naphthalene
Chloroethane	Naphthalene
Chloroform	Propan-2-ol
Chloromethane	Propene
Cyclohexane	Styrene
Dibromochloromethane	1,1,2,2-Tetrachloroethane
1,2-Dibromoethane	Tetrachloroethene
1,2-Dichlorobenzene	Tetrahydrofuran
1,3-Dichlorobenzene	Toluene
1,4-Dichlorobenzene	1,2,4-Trichlorobenzene
Dichlorodifluoromethane (Freon® 12)	1,1,1-Trichloroethane
1,1-Dichloroethane	1,1,2-Trichloroethane
1,2-Dichloroethane	Trichloroethene
1,1-Dichloroethene	Trichlorofluoromethane (Freon® 11)
<i>cis</i> -1,2-Dichloroethene	1,1,2-Trichloro-1,2,2-trifluoroethane (Freon® 113)
<i>trans</i> -1,2-Dichloroethene	1,2,4-Trimethylbenzene
Dichloromethane	1,3,5-Trimethylbenzene
1,2-Dichloropropane	Vinyl acetate
<i>cis</i> -1,3-Dichloropropene	Vinyl chloride
<i>trans</i> -1,3-Dichloropropene	<i>m</i> -Xylene
1,2-Dichlorotetrafluoroethane (Freon® 114)	<i>o</i> -Xylene
1,4-Dioxane	<i>p</i> -Xylene

* Note that the stability of these compounds cannot be guaranteed.

Description	Part number
Standard, gas cylinder, TO-15, 65-component mix, 1 ppm	C-GS15-1PPM
Regulator, high-purity VOC, 0–100 psi outlet	C-GSREG-100

1. ppbC = parts per billion expressed as carbon.

Ozone precursor/PAMS 57-component mix – EPA concentrations 20–60 ppbC¹

Supplied in nitrogen at 1800 psig. Injecting 1 mL of this mix onto a TD cold trap introduces approximately 0.1 ng of the components below (individual concentrations in ppbC¹ are given in parentheses).

Acetylene (40)	Isopropylbenzene (40)
Benzene (30)	Methylcyclohexane (30)
<i>n</i> -Butane (40)	Methylcyclopentane (25)
But-1-ene (30)	2-Methylheptane (25)
<i>cis</i> -But-2-ene (35)	3-Methylheptane (25)
<i>trans</i> -But-2-ene (25)	2-Methylhexane (25)
Cyclohexane (40)	3-Methylhexane (25)
Cyclopentane (20)	2-Methylpentane (20)
<i>n</i> -Decane (30)	3-Methylpentane (40)
<i>m</i> -Diethylbenzene (40)	<i>n</i> -Nonane (25)
<i>p</i> -Diethylbenzene (25)	<i>n</i> -Octane (30)
2,2-Dimethylbutane (40)	<i>n</i> -Pentane (25)
2,3-Dimethylbutane (50)	Pent-1-ene (25)
2,3-Dimethylpentane (50)	<i>cis</i> -Pent-2-ene (35)
2,4-Dimethylpentane (40)	<i>trans</i> -Pent-2-ene (25)
<i>n</i> -Dodecane (40)	Propane (40)
Ethane (25)	<i>n</i> -Propylbenzene (30)
Ethylbenzene (25)	Propene (25)
Ethene (20)	Styrene (40)
<i>m</i> -Ethyltoluene (25)	Toluene (40)
<i>o</i> -Ethyltoluene (30)	1,2,3-Trimethylbenzene (25)
<i>p</i> -Ethyltoluene (40)	1,2,4-Trimethylbenzene (40)
<i>n</i> -Heptane (25)	1,3,5-Trimethylbenzene (25)
<i>n</i> -Hexane (30)	2,2,4-Trimethylpentane (30)
Hex-1-ene (60)	2,3,4-Trimethylpentane (25)
Isobutane (25)	<i>n</i> -Undecane (30)
Isopentane (40)	<i>o</i> -Xylene (25)
Isoprene (40)	<i>m/p</i> -Xylene (combined) (40)

Note that this standard contains some very volatile analytes, and is not suitable for loading onto standard sorbent tubes at ambient temperature.

Description	Part number
Standard, gas cylinder, O ₃ /PAMS, 57-component mix, EPA concentration, 20–60 ppb	C-GSPAMS-EPA
Regulator, high-purity VOC, 0–100 psi outlet	C-GSREG-100



For advice on any aspect of calibration or standards, contact Markes International's technical specialists.

Sampling accessories

An extensive range of sampling accessories for every TD application

Product highlights

- Micro-Chamber/Thermal Extractor™ for quick emissions screening
- SPE-tD™ cartridges for simple sampling of less volatile impurities in liquids
- Time-saving TC-20™ tube conditioner
- Versatile options for headspace-thermal desorption
- Easy-to-use Bio-VOC™ breath sampler
- Cost-effective soil gas monitoring with the VOC-Mole™ soil probe
- Full range of accessories and spares for direct desorption



Contact Markes International for expert advice

Email

enquiries@markes.com

Web

www.markes.com

Telephone

UK: +44 (0)1443 230935

USA: 866-483-5684 (toll-free)

Germany: +49 (0)6102 8825569

Micro-Chamber/Thermal Extractor™

Markes International's Micro-Chamber/Thermal Extractor (μ -CTE™) is the ultimate system for sampling chemical emissions and odour profiles from a wide range of products and materials, quickly and reliably.

It accommodates up to six samples, and is used in conjunction with a TD-GC system to screen multiple samples quickly and cost-effectively. Applications range from routine quality assurance of manufactured goods to rapid aroma profiling of foods and fragranced products.

The Micro-Chamber/Thermal Extractor is available in two models: the six-chamber model (max. 120 °C, with 44 cm³ chambers) and the four-chamber model (max. 250 °C, with 114 cm³ chambers).

Each is compatible with accessories that allow:

- Use of humidified air or gas.
- Permeation testing.
- Assessment of surface emissions.
- Formaldehyde sampling.
- Sampling from liquid or resinous samples.



Part numbers for the 6-chamber Micro-Chamber/Thermal Extractor (max. 120 °C)

Description	Part number
Micro-Chamber/Thermal Extractor, 6-chamber, inert	M-CTE120I
Micro-Chamber/Thermal Extractor, 6-chamber, inert, with 6 toggle valves	M-CTE120TI
Starter kit for Micro-Chamber/Thermal Extractor, inert	M-STUKTI
Sample pan, stainless steel, pk 6	M-MCHSS
Removable lids, stainless steel, pk 6	M-MCTOP
Sample pan, inert, pk 6	M-MCHSI
Removable lids, inert, pk 6	M-MCTOPI

Part numbers for the 4-chamber Micro-Chamber/Thermal Extractor (max. 250 °C)

Description	Part number
Micro-Chamber/Thermal Extractor, 4-chamber, inert	M-CTE250I
Micro-Chamber/Thermal Extractor, 4-chamber, inert, with 4 toggle valves	M-CTE250TI
Starter kit for Micro-Chamber/Thermal Extractor, inert	M-STUKT250I
Sample pan, stainless steel, pk 4	M-MCHSS250
Removable lids, stainless steel, pk 4	M-MCTOP250
Sample pan, inert, pk 4	M-MCHSS250I
Removable lids, inert, pk 4	M-MCTOP250I



For advice on how the Micro-Chamber/Thermal Extractor can aid compliance with construction products regulations, please contact Markes International's technical specialists.



For examples of the Micro-Chamber/Thermal Extractor being used to sample volatiles from:

- Soil – see Application Note 080.
- Car trim – see Application Note 093.
- Cheese – see Application Note 101.
- Building materials – see Application Note 103.

**Accessories for the 6-chamber Micro-Chamber/
Thermal Extractor (max. 120 °C)**

Description	Part number
Humidifier accessory	
Humidifier accessory for Micro-Chamber/Thermal Extractor	M-HUMID-MCTE
Accessories for permeation testing	
Permeation accessory, stainless steel, pk 1	M-PRMIN1
Permeation accessory, stainless steel, pk 6	M-PRMIN
Permeation accessory, inert, pk 1	M-PRMINSS1-120
Permeation accessory, inert, pk 6	M-PRMINSS-120
O-Ring, 30 mm o.d., permeation accessory seal, pk 6	M-PRO30-120
Septa, ¼", for permeation accessory injection port, pk 6	M-PRSPT-120
Accessories for surface emissions testing	
Collar spacer, Al, 15 mm, pk 6	M-SPC15-120
Collar spacer, Al, 5 mm, pk 6	M-SPC05-120
Spacer disc, Al, 1.5 mm, pk 24	M-DSK15-120
Adjustable sprung spacer, pk 6	M-SPGSC-120
Accessories for formaldehyde sampling¹	
O-Ring, size 007, and spacer, to connect 4 mm Luer cartridge, pk 6 (for DNPH cartridges)	M-TCN04
Other accessories	
Sample disc, 1.0 mm thickness, PTFE, pk 6	M-DSKPF
Routine maintenance kit for Micro-Chamber/Thermal Extractor	RMK-0006
Pneumatics accessory (single regulator) ²	U-GAS03
O-Ring, size 010, to connect ¼" o.d. tubes, pk 6 (for standard tubes)	M-TCN64
O-Ring, 5.92 mm i.d., to connect 6 mm o.d. tubes, pk 6	M-TCN06
O-Ring, size 006, for gas line connection to removable lid, pk 6	M-MC006
Tube interface cap for removable lid, pk 6	M-TICAP
O-Ring, micro-chamber pan seal, pk 6	M-MCHOR

 **For more information on the Micro-Chamber/Thermal Extractor and associated accessories and starter kits, download the separate brochure.**

 **For details of cost-effective Micro-Chamber starter kits, see page 48.**

**Accessories for the 4-chamber Micro-Chamber/
Thermal Extractor (max. 250 °C)**

Description	Part number
Humidifier accessory	
Humidifier accessory for Micro-Chamber/Thermal Extractor	M-HUMID-MCTE
Accessories for permeation testing	
Permeation accessory, stainless steel, pk 1	M-PRMIN1-250
Permeation accessory, stainless steel, pk 4	M-PRMIN-250
Permeation accessory, inert, pk 1	M-PRMINSS1-250
Permeation accessory, inert, pk 4	M-PRMINSS-250
O-Ring, 30 mm o.d., permeation accessory seal, pk 4	M-PRO30-250
Septa, ¼", for permeation accessory injection port, pk 6	M-PRSPT-250
Accessories for surface emissions testing	
Collar spacer, Al, 15 mm, pk 4	M-SPC15-250
Collar spacer, Al, 5 mm, pk 4	M-SPC05-250
Spacer disc, Al, 1.5 mm, pk 24	M-DSK15-250
Adjustable sprung spacer, pk 4	M-SPGSC-250
Accessories for formaldehyde sampling¹	
O-Ring, size 007, and spacer, to connect 4 mm Luer cartridge, pk 6 (for DNPH cartridges)	M-TCN04
Other accessories	
Sample disc, 1.0 mm thickness, PTFE, pk 6	M-DSKPF
Inserts for liquid standard introduction, PTFE, pk 6	M-TSTIN
Routine maintenance kit for Micro-Chamber/Thermal Extractor	RMK-0006HT
Pneumatics accessory (single regulator) ²	U-GAS03
O-Ring, size 010, to connect ¼" o.d. tubes, pk 6 (for standard tubes)	M-TCN64
O-Ring, 5.92 mm i.d., to connect 6 mm o.d. tubes, pk 6	M-TCN06
O-Ring, size 006, for gas line connection to removable lid, pk 6	M-MC006
Tube interface cap for removable lid, pk 6	M-TICAP
O-Ring, micro-chamber pan seal, standard (for applications <200 °C), pk 4	M-MCHOR250

1. DNPH cartridges are not included.

2. Markes recommends that a pneumatics accessory (U-GAS03, page 62) is used with every Micro-Chamber/Thermal Extractor.

SPE-tD™ cartridges

Markes International's SPE-tD sorptive extraction cartridges are a simple way of sampling less volatile impurities in aqueous samples – applications that would otherwise require manually intensive extraction or distillation before GC analysis.

For optimum sampling capacity, SPE-tD cartridges are constructed in the form of a hollow tube, coated inside and out with poly(dimethylsiloxane) (PDMS).

The cartridge is simply placed into the sample and agitated, before being removed, rinsed, and placed into an empty TD tube for analysis by direct TD-GC. This allows semi-quantitative analysis of less volatile organics, and direct comparison of organic chemical concentrations in two similar samples.



Description	Part number
SPE-tD cartridge (30 mm), pk 1	C-SPTD1
SPE-tD cartridge (30 mm), pk 5	C-SPTD5
SPE-tD cartridge (30 mm), pk 10	C-SPTD10
SPE-tD cartridge (6 mm), pk 1	C-SPTD1-6MM
SPE-tD cartridge (6 mm), pk 5	C-SPTD5-6MM
SPE-tD cartridge (6 mm), pk 10	C-SPTD10-6MM
Starter kit for SPE-tD	C-KITSP-2S

i For details of Markes International's cost-effective SPE-tD starter kit, see page 47.

↓ For examples of the use of SPE-tD cartridges to sample:

- Fruit juices and wine – see Application Note 088.
- Beer – see Application Note 094.



To order your SPE-tD cartridges, simply telephone or send an email.



TC-20™ multi-tube conditioner and dry-purge unit

Markes International's TC-20 saves time and money by freeing up your TD instrument to run samples rather than condition tubes.

With temperatures up to 400°C and capacity for up to 20 industry-standard sorbent tubes, the TC-20 passes a uniform flow of inexpensive nitrogen through each attached tube at a constant rate – guaranteeing clean tubes whatever the sorbent packing. Up to 20 tubes can also be reliably and simultaneously dry-purged.



Description	Part number
TC-20 multi-tube conditioner and dry-purge unit (115 V)	R-TC20-1
TC-20 multi-tube conditioner and dry-purge unit (230 V)	R-TC20-2
Filter for TC-20, carbon, 120 mm × 120 mm, pk 4 (replacement filters for cooling fan at rear of TC-20)	R-FLTR4

↓ **The cost savings that can be made by using off-line conditioning on the TC-20 are explored in Application Note 109.**

↓ **For more information on the TC-20 or Markes International's headspace-TD solutions, download the respective brochures.**

Headspace-thermal desorption



Combining headspace with TD offers optimum sensitivity for trace VOCs in solid, liquid and vapour-phase samples, all on one versatile analytical platform.

Headspace-TD is typically 10–100 times more sensitive than static equilibrium headspace, and offers increased

recovery of higher-boiling

analytes. It offers similar detection limits to purge-and-trap but with no foaming or aerosol issues, and allows selective elimination of matrix components such as water and methanol.

Markes International's UNITY thermal desorber can be coupled with:

- Fully-automated third-party equilibrium headspace units.
- The HS5-TD™ unit – Markes' entry-level HS module for up to five vials.
- Markes' manual Universal Direct Inlet Accessory for focusing vapours directly on the cold trap.

Description	Part number
HS5-TD headspace system	U-HS5TD
HS-TD connection kit, UNITY(e) to G1290	U-HSTD-G1290
HS-TD connection kit, UNITY(e) to G1888	U-HSTD-G1888
HS-TD connection kit, UNITY(e) to HS40	U-HSTD-HS40
Starter kit for HS5-TD	U-HSKIT
Vials, crimp-top, 20 mL, clear, pk 1000	U-HSV00
Crimps, 20 mm aluminium cap, silicone/PTFE liner, pk 1000	U-HSVC0
Crimper, 20 mm crimp-top vials	U-HSVCR
Decapper, 20 mm crimp-top vials	U-HSVDC
Routine maintenance kit for HS5-TD	RMK-0008
Replacement needle assembly for HS5-TD	U-HSNAS
Universal Direct Inlet Accessory (U-INLET)	U-INLET
Pump (115 V)	U-ASPM1
Pump (230 V)	U-ASPM2

↓ **For examples of the use of headspace-TD, see Application Notes 078, 088, 091 and 096.**

Bio-VOC™ breath sampler



Markes International's Bio-VOC is a simple, disposable device for collecting alveolar (end-tidal) breath samples and transferring them quantitatively to sorbent tubes. It is used for non-invasive biological exposure monitoring of VOCs.

Constructed of safe, non-emitting plastic, and based on pioneering work carried out at the UK Health & Safety Laboratory, the Bio-VOC can be operated with minimal training, and without medically qualified staff in attendance.



Description	Part number
Bio-VOC breath sampler, pk 1	C-BIO01
Bio-VOC breath sampler, pk 10	C-BIO10
Bio-VOC breath sampler, pk 50	C-BIO50
Bio-VOC breath sampler, pk 100	C-BIO100
Disposable cardboard mouthpieces, pk 100	C-B100M

↓ For more information on Bio-VOC and example applications, download **Application Note 013**.

VOC-Mole™ soil probe

With a robust, high-quality stainless steel construction, Markes International's VOC-Mole is an economical way to sample VOCs in contaminated land, or along fuel pipelines.

Monitoring typically uses diffusive tubes held inside the VOC-Mole, but pumped sampling is also possible. The VOC-Mole is available in three probe lengths, and there is also a modified version for use in marshy ground.



Description	Part number
VOC-Mole assembly, 29.5 cm long, pk 1	P-0001
VOC-Mole assembly, 29.5 cm long, pk 10	P-00010
VOC-Mole assembly, 44.5 cm long, pk 10	P-00020
VOC-Mole assembly, 89.5 cm long, pk 10	P-00030
VOC-Mole assembly, 89.5 cm long, modified for use in marshy ground, pk 10	P-00040
VOC-Mole cap assembly, pk 1	P-CP001
VOC-Mole cap assembly, pk 10	P-CP010
Brass impact former for driving soil probes into the ground	P-FORMR
O-Rings, for VOC-Mole cap assembly, 23 mm × 3 mm i.d., pk 20	P-CP020
Unions, for VOC-Mole cap assembly, pk 10	P-CPU10
Blanking plugs, for VOC-Mole cap assembly, pk 10	P-CP010
Dowty seals, for VOC-Mole cap assembly, pk 20	P-CPS20
Ferrules, PTFE, for VOC-Mole cap assembly, pk 10	P-CPF10

↓ For more information on VOC-Mole and example applications, download **Application Note 029**.

Direct desorption

Direct desorption is a highly effective, cost-saving technique that can be used to rapidly screen small quantities of homogeneous solid (or semi-solid) materials.

Samples are simply weighed into empty TD tubes (using a tube liner if needed), and placed in the thermal desorber. They are then heated in a stream of inert gas to dynamically extract headspace volatiles directly onto the focusing trap.

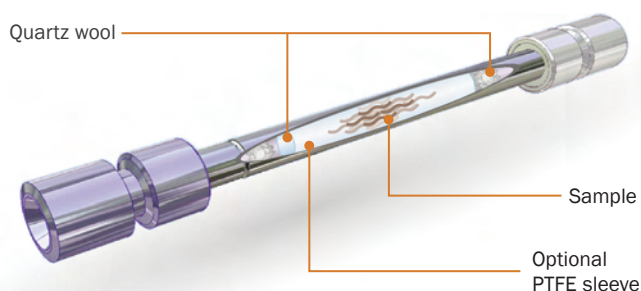

Direct desorption avoids labour-intensive manual sample preparation, and improves method stability by eliminating interferences such as non-volatiles, water and solvents prior to analysis.

Description	Part number
Tube, empty, glass, restriction at 30 mm, pk 10	C0-NXXX-0000
Tube, empty, glass, restriction at 15 mm, pk 10	C0-BXXX-0000
Tube, empty, glass, unrestricted, pk 10	C0-FXXX-0000
Tube, empty, stainless steel, pk 10	C0-AXXX-0000
Tube, empty, inert, pk 10	C0-CXXX-0000
Liner, PTFE, snug-fit, pk 10	C-PI010
Liner, PTFE, snug-fit, pk 100	C-PI100
Liner, PTFE, loose-fit, pk 10	C-PL010
Liner, PTFE, loose-fit, pk 100	C-PL100
Direct desorption starter kit	C-KITDD-2S

↓ For a more detailed description of direct desorption, see Application Note 009.

i For details of Markes International's cost-effective T0-15 starter kit, see page 45.

↓ For examples of the use of direct desorption to analyse:

- Paint, polymers and adhesives – see Application Notes 057, 103 and 108.
- Car trim (in accordance with VDA Method 278) – see Application Note 059.



To order your direct desorption tubes and accessories, simply telephone or send an email.

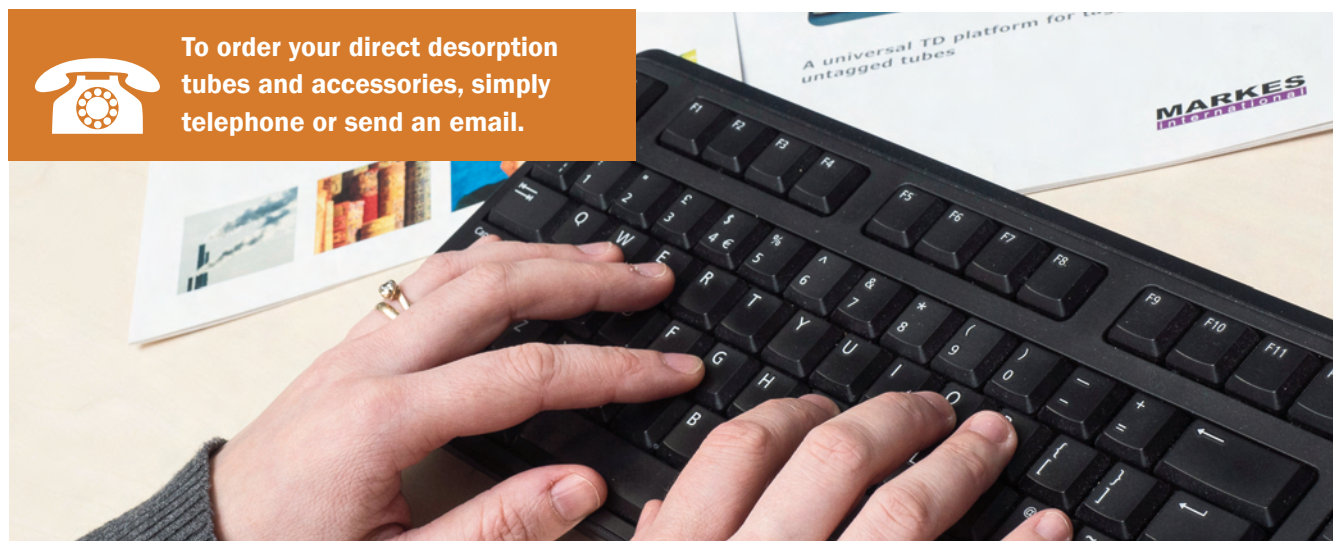

Thermal analysis and evolved gas collection

Thermal desorption is a convenient way of investigating the gases evolved during thermogravimetric analysis (TGA) and microthermal analysis – using these specially designed sorbent-packed MacroTubes™ (TGA analysis) or MicroTubes™ (microthermal analysis).



Description	Part number
MacroTubes, general screening (n-C ₅ to n-C ₃₀), conditioned and capped, pk 5	E-MATBG5
MacroTubes, high volatility (C ₃ to n-C ₁₀), conditioned and capped, pk 5	E-MATBV5
Macro connector	E-MACNT
Macro connector carrier	E-MACAR
MicroTubes, general screening (n-C ₅ to n-C ₃₀), condition before use, pk 5	E-MITBE5
MicroTubes, general screening (n-C ₅ to n-C ₃₀), condition before use, pk 50	E-MITBE50
MicroTube carrier	E-MICAR
MicroTube carriers, pk 10	E-MICAR10
O-Ring, chemically inert, spare for MicroTube carrier	E-MICOR

Custom solutions

Over the years, Markes International has developed custom solutions for numerous TD users – from special-dimension DAAMS tubes to tailored TubeTAG data-input screens and multiple application-specific sampling accessories.

Whatever your requirements, Markes' specialists would be delighted to work with you to develop a custom solution precisely meeting your needs.



Talk to Markes International's specialists to discuss custom solutions for your application.

Starter kits

Handy packages of tubes, traps, tools and accessories to get you up and running quickly

Product highlights

- General-purpose TD starter kits for UNITY™ and TD-100™
- Specialist kits for military, environmental and material emissions applications
- Convenient kits for specific instruments and accessories



**Contact Markes
International for
expert advice**

Email

enquiries@markes.com

Web

www.markes.com

Telephone

UK: +44 (0)1443 230935

USA: 866-483-5684 (toll-free)

Germany: +49 (0)6102 8825569

Markes' general TD starter kits

Two economical general-purpose starter kits (with 3½" tubes) are available for UNITY 2 and TD-100 users.

The **Basic TD starter kit** contains:

Stainless steel sorbent tubes, conditioned and capped, pk 10 <i>Suitable for pumped sampling of VOCs from n-C_{5/6} to n-C_{30/32}</i>	C2-AAXX-5032
CapLok tool for tightening and undoing ¼" brass storage caps	C-CPLOK
Cold trap, general-purpose carbon, UNITY 2/TD-100, n-C _{4/5} to n-C _{30/32}	U-T11GPC-2S
Quick-seal column connector, pk 10	C-QSC10

The **Advanced TD starter kit** contains:

Universal stainless steel sorbent tubes, conditioned and capped, pk 10 <i>Suitable for pumped sampling of VOCs from C_{2/3} to n-C_{30/32}</i>	C3-AAXX-5266
Stainless steel sorbent tubes, conditioned and capped, pk 10 <i>Suitable for pumped sampling of VOCs from n-C_{5/6} to n-C_{30/32}</i>	C2-AAXX-5032
Tenax TA stainless steel sorbent tubes, conditioned and capped, pk 10 <i>Suitable for pumped or diffusive sampling of VOCs from n-C_{6/7} to n-C_{30/32}</i>	C1-AAXX-5003
Diffusion caps, pk 10	C-DF010
Empty stainless steel tubes, pk 10	C0-AXXX-0000
Quartz wool, 10 g	C-QUTZW
Spring, gauze-retaining, pk 10	C-SP010
Penclip, pk 10	C-CL010
Ferrule, ¼" PTFE, pk 20	C-FP020
PTFE liners, loose fit, pk 10	C-PL010
Cold trap, TO-15/TO-17 air toxics, UNITY 2/ TD-100 <i>Compatible with the simultaneous analysis of analytes from C_{2/3} to n-C_{30/32}</i>	U-T15ATA-2S
Easy-VOC pump, including CapLok tool and carry-case	C-EZVOCPO
Check-standard (BTX, isobornyl methacrylate (IBMA) and dioctyl phthalate), 90 ng/µL (nominal), Tenax TA, pk 10	C-CHK10

Description	Part number
Basic TD starter kit	C-KIT012-2S
Advanced TD starter kit	C-KIT03-2S

Application-specific starter kits

Military and homeland defence applications

The **CWA starter kit** is compatible with standard UNITY 2 or TD-100 systems, and is intended specifically for analysts in the field of military and homeland defence. It contains:

Inert-coated stainless steel 3½" × ¼" o.d. sorbent tubes, conditioned and capped, pk 10 <i>Suitable for sampling of G-type nerve agents, mustard gas (HD) and VX</i>	C2-CAXX-5138
Inert-coated stainless steel 3½" × ¼" o.d. sorbent tubes, conditioned and capped, pk 10 <i>Suitable for sampling of G-type nerve agents, mustard gas (HD), VX and the G-analogue of VX</i>	C2-CAXX-5250
Cold trap, chemical warfare agents, UNITY 2/ TD-100 <i>Compatible with the simultaneous analysis of all the above-mentioned analytes</i>	U-T10CW-2S

Description	Part number
CWA starter kit	C-KITCW-2S

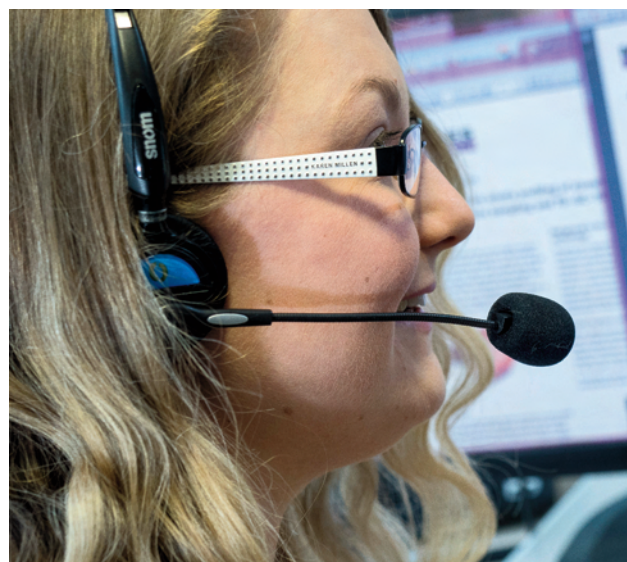

To order any of Markes' kits, simply telephone or send an email.

Environmental monitoring applications

The **Basic environmental starter kit** is suitable for pumped-tube sampling. It contains:

Stainless steel tubes, conditioned and capped, pk 10 <i>Suitable for pumped sampling of VOCs from n-C₄ to n-C_{30/32}</i>	C2-AAXX-5149
Cold trap, TO-15/TO-17 air toxics, UNITY 2/ TD-100 <i>Compatible with the simultaneous analysis of analytes from C_{2/3} to n-C_{30/32}</i>	U-T15ATA-2S
Easy-VOC pump, including CapLok tool and carry-case	C-EZVOCPO

The **Diffusive monitoring starter kit** is perfect for TD users new to diffusive (passive) air sampling. It contains:

Tenax TA stainless steel tubes, conditioned and capped, pk 10	C1-AAXX-5003
Carbograph 1TD stainless steel tubes, conditioned and capped, pk 10	C1-AAXX-5009
Diffusion caps, aluminium, 2 × pk 10	2 × C-DF010
CapLok tool for tightening and undoing ¼" brass storage caps	C-CPLOK
Pencilips, 2 × pk 10	2 × C-CL010
Cold trap, TO-15/TO-17 air toxics, UNITY 2/ TD-100 <i>Compatible with the simultaneous analysis of analytes from C_{2/3} to n-C_{30/32}</i>	U-T15ATA-2S
Certified reference standard (BTX), 100 ng, pk 10 (includes certificate, chromatogram and shipping blank)	C-BTX100-10

The **TO-15 starter kit** is ideal for analysts setting up canister-based sampling compliant with US EPA Method TO-15. The kit contains:

Cold trap, TO-15/TO-17 air toxics, UNITY 2/ TD-100 <i>Compatible with the simultaneous analysis of analytes from C_{2/3} to n-C_{30/32}</i>	U-T15ATA-2S
5 × TO-Can, 1 L, with gauge and ¼" valve	5 × C-TOCAN1
2 × Canister air sampling kit, stainless steel	2 × C-ASK1168SS
Frit, stainless steel, for critical orifice, pk 3	C-ASK2USS

The **TO-17 starter kit** is perfect for monitoring 'air toxics' using pumped tubes in compliance with US EPA Method TO-17. The kit contains:

Air toxics glass tubes, conditioned and capped, pk 10 <i>Suitable for pumped sampling of VOCs from C_{2/3} to n-C₁₄</i>	C2-BAXX-5259
Universal stainless steel tubes, conditioned and capped, pk 10 <i>Suitable for pumped sampling of VOCs from C_{2/3} to n-C_{30/32}</i>	C3-AAXX-5266
CapLok tool for tightening and undoing ¼" brass storage caps	C-CPLOK
Cold trap, TO-15/TO-17 air toxics, UNITY 2/ TD-100 <i>Compatible with the simultaneous analysis of analytes from C_{2/3} to n-C_{30/32}</i>	U-T15ATA-2S
Certified reference standard, 9-component TO-17 mix, 100 ng, pk 10 (plus certificate, chromatogram and shipping blank)	C-TO17XX-10



For examples of Markes' technology being used in real-world situations, contact Markes to order the relevant **Practical Applications Guide**.

Description	Part number
Basic environmental starter kit	C-KITEV01-2S
Diffusive monitoring starter kit	C-KITEV02-2S
TO-15 starter kit	C-KITEV03-2S
TO-17 starter kit	C-KITEV04-2S

Material emissions applications

The **Basic material emissions starter kit** is ideal for those carrying out routine in-house tests of product emissions in compliance with ISO 16000, ISO 12219 or equivalent ASTM standards. It contains:

Tenax TA inert-coated stainless steel sorbent tubes, conditioned and capped, pk 10 <i>Suitable for sampling VOCs from n-C_{6/7} to n-C_{30/32}</i>	C1-CAXX-5003
Material emissions stainless steel sorbent tubes, conditioned and capped, pk 10 <i>Suitable for sampling VOCs from n-C₄ to n-C₃₂</i>	C3-AAXX-5304
CapLok tool for tightening and undoing ¼" brass storage caps	C-CPLOK
Cold trap, material emissions <i>Compatible with the simultaneous analysis of analytes from n-C₄ to n-C₃₂</i>	U-T12ME-2S
Quick-seal column connector, pk 10	C-QSC10

The **Comprehensive material emissions starter kit** provides a wider range of parts ideal for high-throughput service or manufacturing laboratories carrying out product emissions testing using standard reference or screening methods. It contains:

Tenax TA inert-coated stainless steel sorbent tubes, conditioned and capped, 2 x pk 10 <i>Suitable for sampling VOCs from n-C_{6/7} to n-C_{30/32}</i>	2 x C1-CAXX-5003
Material emissions stainless steel sorbent tubes, conditioned and capped, 2 x pk 10 <i>Suitable for sampling VOCs from n-C₄ to n-C₃₂</i>	2 x C3-AAXX-5304
Glass sorbent tube with restriction at 30 mm, empty, for direct desorption, pk 10	C0-NXXX-0000
CapLok tool for tightening and undoing ¼" brass storage caps	C-CPLOK
Spring, gauze-retaining, pk 10	C-GTSP10
Quartz wool, 10 g	C-QUTZW
Ferrule, PTFE, one-piece, pk 20	C-FP020
Check-standard (material emissions), 100 ng, Tenax TA, pk 10	C-CHK10-ME
Cold trap, material emissions <i>Compatible with the simultaneous analysis of analytes from from n-C₄ to n-C₃₂</i>	U-T12ME-2S
Quick-seal column connector, pk 10	C-QSC10

The **Direct desorption starter kit** is a cost-effective pack of consumables for measuring chemical content or emissions from small samples of materials, according to VDA 278 or equivalent methods. It contains:

Glass tubes, empty, restriction at 30 mm, pk 10	C0-NXXX-0000
Stainless steel tubes, empty, pk 10	C0-AXXX-0000
Cold trap, material emissions, UNITY 2/ TD-100 <i>Compatible with the simultaneous analysis of analytes from n-C₄ to n-C₃₂</i>	U-T12ME-2S
PTFE liners, snug-fit, pk 10	C-PI010
PTFE liners, loose-fit, pk 10	C-PL010
Quartz wool, 10 g	C-QUTZW
Sorbent, Tenax TA (35/60), 10 g	C-TNXTA
Springs, torsion, for 4 mm i.d. glass tubes, pk 10	C-GTSP10

Description	Part number
Basic material emissions starter kit	C-KITME01-2S
Comprehensive material emissions starter kit	C-KITME02-2S
Direct desorption starter kit	C-KITDD-2S

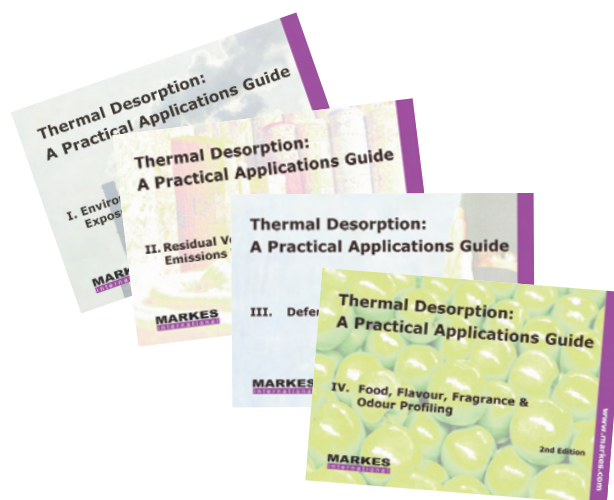

For examples of Markes' technology being used in real-world situations, contact Markes to order the relevant *Practical Applications Guide*.

Product-specific starter kits

Markes International offers a range of product-specific kits as a cost-effective way of getting started with your application.

Markes' **TubeTAG starter kit** for stainless steel tubes is available in a convenient carry-case.



The kit contains:

TAG ^{SCRIBE} read/write device for all TubeTAGs	C-SCRIBE
TubeTAG for stainless steel tubes, pk 10	C-TAG10
TubeTAG fixing/removal tool for 1/4" stainless steel tubes	C-TAGTL
Cap, brass, 1/4" & PTFE ferrule (one standard, one tag-ready), pk 10 pairs, for 1/4" metal tubes	C-TCFP10
TAGLok tool for tightening/removing standard and TAG-ready 1/4" storage caps	C-TAGLOK



Markes' **Easy-VOC starter kit**, with versatile three-bed SafeLok sorbent tubes, contains:

Easy-VOC pump (plus CapLok tool and carry-case)	C-EZVOCPO
Air toxics stainless steel SafeLok sorbent tubes, conditioned and capped, pk 10 <i>For pumped sampling of VOCs from C_{3/4} to C₃₀</i>	C3-DAXX-5266



Markes' **SPE-tD starter kit** for sorptive extraction of volatiles from liquids, contains:

SPE-tD cartridges (30 mm length), pk 5	C-SPTD5
Glass tubes, empty, restriction at 15 mm, pk 10	C0-BXXX-0000
Springs, torsion, for 4 mm i.d. glass tubes, pk 10	C-GTSP10
Quartz wool (10 g)	C-QUTZW
Cold trap, Tenax TA, UNITY 2/TD-100	U-T9TNX-2S
Cap, storage, brass, 1/4" & PTFE ferrule, pk 20	C-CF020

Description	Part number
TubeTAG starter kit (for stainless steel tubes)	C-TAGKT
Easy-VOC starter kit	C-EZVOCKT
Starter kit for SPE-tD	C-KITSP-2S
Starter kit for Micro-Chamber/Thermal Extractor, 6-chamber, inert	M-STUKTI
Starter kit for Micro-Chamber/Thermal Extractor, 4-chamber, inert	M-STUKT250I



To order any of Markes' kits, simply telephone or send an email.

Markes' **starter kit for the 6-chamber Micro-Chamber/Thermal Extractor** (max. 120 °C) contains:

Sample pans, inert-coated, pk 6	M-MCHSI
Detachable sample lids, inert-coated, pk 6	M-MCTOPI
Tube interface caps, pk 6	M-TICAP
M4 flanged nuts for removable lids, pk 6	SERZ-NM4FLGSS
Nut driver tool (for releasing lids)	SERZ-0669
Adjustable sprung spacers, pk 6	M-SPGSC-120
Aluminium collar spacers (15 mm), pk 6	M-SPC15-120
Aluminium collar spacers (5 mm), pk 6	M-SPC05-120
Aluminium spacer discs (1.5 mm), pk 24	M-DSK15-120
Routine maintenance kit (selection of O-rings)	RMK-0006
Inert-coated stainless steel tubes, packed with Tenax TA, conditioned and capped, 2 × pk 10	2 × C1-CAXX-5003
CapLok tool	C-CPLOK

Markes' **starter kit for the 4-chamber Micro-Chamber/Thermal Extractor** (max. 250 °C) contains:

Sample pans, inert-coated, pk 4	M-MCHSS250I
Detachable sample lids, inert-coated, pk 4	M-MCTOP250I
Tube interface caps, pk 6	M-TICAP
M3 hexagonal ball driver (spanner)	SERZ-0861
Adjustable sprung spacer assemblies, pk 4	M-SPGSC-250
Aluminium collar spacers (15 mm), 2 × pk 4	2 × M-SPC15-250
Aluminium collar spacers (5 mm), 3 × pk 4	3 × M-SPC05-250
Aluminium spacer disks (1.5 mm), pk 24	M-DSK15-250
Liquid sample inserts, pk 4	M-TSTIN
Routine maintenance kit (selection of O-rings)	RMK-0006HT
Inert-coated stainless steel tubes, packed with Tenax TA, conditioned and capped, pk 10	C1-CAXX-5003
CapLok tool	C-CPLOK

Description	Part number
Starter kit for Micro-Chamber/Thermal Extractor, 6-chamber, inert	M-STUKTI
Starter kit for Micro-Chamber/Thermal Extractor, 4-chamber, inert	M-STUKT250I
Automated TD starter kit, for 3½" tubes	U-ULKIT
Automated TD starter kit, for 4½" tubes	U-ULKIT-XZ

The **Automated TD starter kit** for the ULTRA 2 autosampler and TD-100, compatible with 3½" (standard) tubes, contains:

Cap, DiffLok, stainless steel, ¼", pk 160 <i>(sufficient for 80 tubes, for routine analysis)</i>	C-DL160
O-Rings, size 007, pk 10 <i>(for ULTRA tube receiver)</i>	U-COV07
O-Rings, size 010, pk 10 <i>(for tube interface seal)</i>	U-COV10

The **Automated TD starter kit** for the ULTRA-X (the model of the ULTRA 2 autosampler compatible with 4½" tubes with 6 mm o.d. ends) contains:

Cap, DiffLok, pk 80 pairs (80 stainless steel, 80 inert-coated) <i>(sufficient for 80 tubes, for routine analysis)</i>	C-DLP80-XZ
O-Rings, size 007, pk 10 <i>(for ULTRA tube receiver)</i>	U-COV07
O-Rings, 5.92 mm i.d., pk 10 <i>(for tube interface seal)</i>	U-COV45



To order any of Markes' kits, simply telephone or send an email.

Instrument spares

Spares and accessories for all
Markes International's TD systems

Product highlights

- Single source for all Markes' instrument spares
- Genuine high-quality Markes spares
- Routine maintenance kits to ensure ongoing high performance



**Contact Markes
International for
expert advice**

Email

enquiries@markes.com

Web

www.markes.com

Telephone

UK: +44 (0)1443 230935

USA: 866-483-5684 (toll-free)

Germany: +49 (0)6102 8825569

TD-100™

Cryogen-free automated thermal desorber

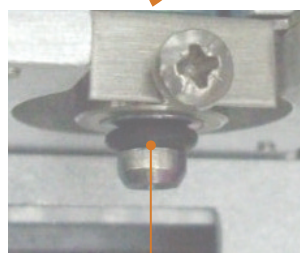
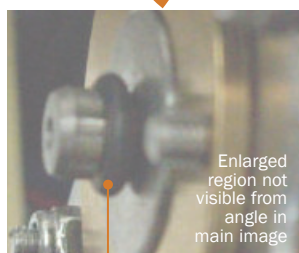
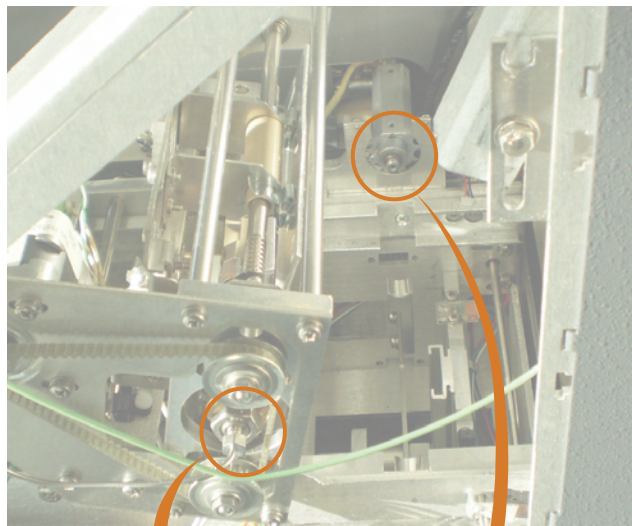

O-Ring,
low-emission,
size 007
U-COV07

Cables

Description	Part number
Cable assembly, lead, null modem (PC to TD communications cable; two per instrument)	SERZ-0189
Cable assembly, UNITY 2 to GC, standard	SERUTE-5141
Cable assembly, UNITY 2 to GC, Agilent	SERUTE-5142
Cable assembly, UNITY 2 to GC, Thermo	SERUTE-5143
Cable assembly, UNITY 2 to GC, Varian/Bruker	SERUTE-5144

Miscellaneous

Description	Part number
O-Ring, low-emission, size 006, pk 10	U-COV06
O-Ring, low-emission, size 007, pk 10	U-COV07
O-Ring, low-emission, size 010, pk 10	U-COV10
O-Ring, low-emission, size 010, pk 100	U-COV100
Ferrule, 1/16" x 0.4 mm graphite/Vespel, pk 10 (connects fused silica transfer line)	U-FV001
Ferrule, 1/16" x 1/16" graphite/Vespel, pk 10 (PEEK connections/bypass line/bulkhead union)	U-FV002
Ferrule, 1/8" x 1/16" graphite/Vespel, pk 10 (PEEK connections/gas supply connections)	U-FV003
ULTRA/TD-100 O-ring insertion tool	SERMTD-1382
Fused silica transfer line insert (0.25 mm i.d.) and PTFE sleeve	SERUTD-5093
Split filter tube, stainless steel, 3 1/2", packed with charcoal	SERUTD-5065
Filter, disk, sintered PTFE, 5.1 mm section, pk 10	U-DISK1
Tray assemblies for autosampler, 3 1/2", including 20 tray labels, pk 10	U-TRAY
Labels, autosampler tray, 3 1/2", strip of 10, blue	SERMTD-1213BU
Quick-seal column connector, pk 10 (connects fused silica to column)	C-QSC10



For more information on any of Markes International's products, download the brochures from Markes' website.



UNITY™ 2

Second-generation cryogen-free single-tube thermal desorber

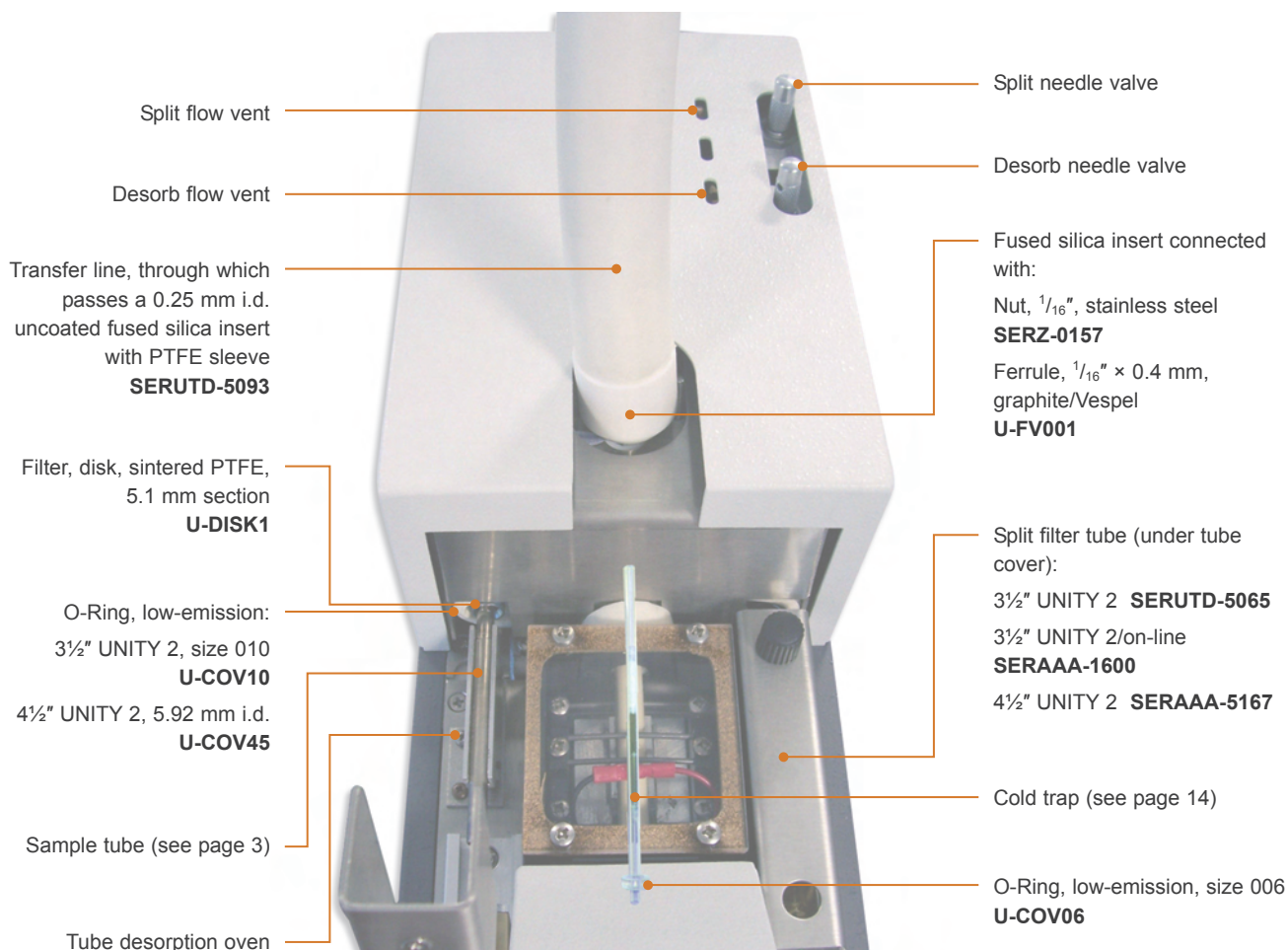

Please see next page for spares listing.



To order any of Markes International's instrument spares, simply telephone or send an email.

1. UNITY 1 cables are also compatible with UNITY 2.

UNITY 2 (continued)

General (see diagram on previous page)

Description	Part number
O-Ring, low-emission, size 006, pk 10	U-COV06
O-Ring, low-emission, size 010, pk 10	U-COV10
O-Ring, low-emission, size 010, pk 100	U-COV100
O-Ring, low-emission, 5.92 mm i.d., pk 10	U-COV45
Split filter tube, stainless steel, 3½", packed with charcoal	SERUTD-5065
Split filter tube, glass, 3½", packed with charcoal (used for on-line systems)	SERAAA-1600
Split filter tube, glass, 4½", packed with charcoal	SERAAA-5167
Fused silica transfer line insert (0.25 mm i.d.) and PTFE sleeve	SERUTD-5093
Ferrule, 1/16" × 0.4 mm graphite/Vespel, pk 10 (connects fused silica transfer line)	U-FV001
Ferrule, 1/16" × 1/16" graphite/Vespel, pk 10 (PEEK connections/bypass line/bulkhead union)	U-FV002
Ferrule, 1/8" × 1/16" graphite/Vespel, pk 10 (PEEK connections/gas supply connections)	U-FV003
Filter, disk, sintered PTFE, 5.1 mm section, pk 10	U-DISK1
Quick-seal column connector, pk 10 (connects fused silica to column)	C-QSC10
Nut, 1/16", for unions, stainless steel (to connect fused silica insert)	SERZ-0157

Cables¹

Description	Part number
Cable assembly, lead, null modem (PC to TD communications cable)	SERZ-0189
Cable assembly, UNITY 2 to GC, standard	SERUTE-5141
Cable assembly, UNITY 2 to GC, Agilent	SERUTE-5142
Cable assembly, UNITY 2 to GC, Thermo	SERUTE-5143
Cable assembly, UNITY 2 to GC, Varian/Bruker	SERUTE-5144

1. UNITY 1 cables are also compatible with UNITY 2.

Tools and installation connections

Description	Part number
O-Ring insertion tool	SERZ-0285
O-Ring extraction tool	SERZ-0351
O-Ring service kit, 3½" tubes only (includes U-COV10, U-DISK1, SERZ-0285, SERZ-0351)	U-ORKIT
Tube extractor tool	SERUTD-5062
Trap alignment tool	SERUTD-5064
Standard tool kit	SERUTD-5063
UNITY-to-GC transfer line clamp (for use as spacer inside GC oven)	SERUTD-1125
Washer, ¼" × 1" (for use with SERUTD-1125)	SERZ-0371
Washer, ¼" × 1½" (for use with SERUTD-1125)	SERZ-0372
Nut, ¼"-20 UNC, stainless steel, for end of transfer line	SERZ-NU14SS
Quick-seal column connector, pk 10	C-QSC10

Miscellaneous

Description	Part number
UNITY 2 software CD (includes automation)	U-SW001-2S
Markes' technical manual for series 2 TD systems on CD	U-TECHCD
UNITY to UNITYe conversion kit (converts UNITY 2 from manual to electronic carrier control)	SERUTE-5103
UNITY 2 tube oven conversion kit, 3½" to 4½" (user-installable)	U-35TO45KT
UNITY 2 tube oven conversion kit, 4½" to 3½" (user-installable)	U-45TO35KT
Mass flow controller (MFC), digital, 2–500 mL/min	U-DMFC-2S
Universal Direct Inlet Accessory, 3½"	U-INLET
Universal Direct Inlet Accessory, 4½"	U-INLET-XZ



For more information on any of Markes International's products, download the brochures from Markes' website.

ULTRA™ 2

Autosampler for the UNITY thermal desorber

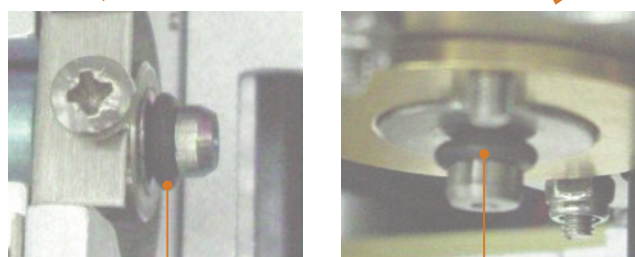
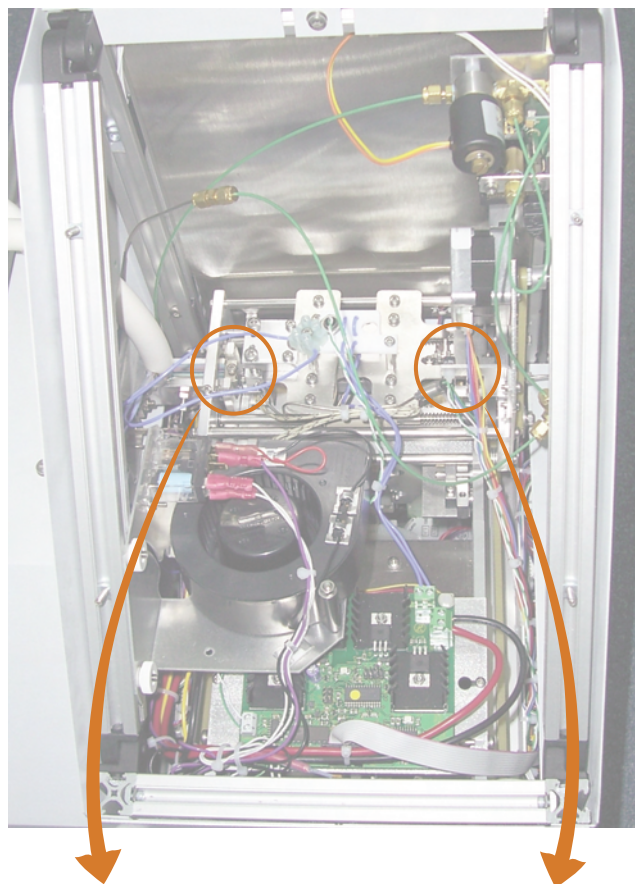

O-Ring,
low-emission,
size 007
U-COV07



To order any of Markes International's instrument spares, simply telephone or send an email.

Description	Part number
Cap, DiffLok, stainless steel, 1/4", pk 10	C-DL010
Cap, DiffLok, stainless steel, 1/4", pk 100	C-DL100
Cap, DiffLok, inert, 1/4", pk 10	C-DLS10
Cap, DiffLok, inert, 1/4", pk 100	C-DL1S0
Cap, DiffLok, one stainless steel, one inert-coated, 1/4", pk 10 pairs	C-DLP10
Cap, DiffLok, one stainless steel, one inert-coated, 1/4", pk 100 pairs	C-DL1P0
Cap, DiffLok, stainless steel, 6 mm, pk 10	C-DL010-XZ
Cap, DiffLok, stainless steel, 6 mm, pk 100	C-DL100-XZ
Cap, DiffLok, inert, 6 mm, pk 10	C-DLS10-XZ
Cap, DiffLok, inert, 6 mm, pk 100	C-DL1S0-XZ
Cap, DiffLok, one stainless steel, one inert-coated, 6 mm, pk 10 pairs	C-DLP10-XZ
Cap, DiffLok, one stainless steel, one inert-coated, 6 mm, pk 100 pairs	C-DL1P0-XZ
O-Ring, low-emission, size 010, pk 10 (for 1/4" DiffLok caps)	U-COV10
O-Ring, low-emission, size 010, pk 100 (for 1/4" DiffLok caps)	U-COV100
O-Ring, low-emission, 5.92 mm i.d., pk 10 (for 6 mm DiffLok caps)	U-COV45
O-Ring, low-emission, size 007, pk 10 (ULTRA tube receiver)	U-COV07
Tray assemblies for autosampler, 3 1/2", including 20 tray labels, pk 10	U-TRAY
Labels, autosampler tray, 3 1/2", strip of 10, blue	SERMTD-1213BU
Tray assemblies for ULTRA, 4 1/2", including 20 tray labels, pk 10	U-TRAY-XZ
Labels, ULTRA tray, 4 1/2", strip of 10, blue	SERMTD-1394BU
ULTRA/TD-100 U-COV07 O-ring insertion tool	SERMTD-1382
AutoSecureTD interface kit, 3 1/2" (to add a second ULTRA 2 to UNITY 2)	U-USKIT-2S
AutoSecureTD interface kit, 4 1/2" (to add a second ULTRA 2 to UNITY 2)	U-USKIT-XZ
AutoSecureTD interface kit, 3 1/2" (to add a second ULTRA 2 to UNITY 1)	U-USKIT
TubeTAG read/write option for ULTRA 2	U-TAGRW-2S
Connection kit, to connect series 2 Air Server 3/8 and ULTRA 2 to the same UNITY 2, 3 1/2"	U-UASK2-2S
Connection kit, to connect series 2 Air Server 3/8 and ULTRA 2 to the same UNITY 2, 4 1/2"	U-UASK2-XZ

Air Server™ and Canister Interface Accessory (CIA) systems

UNITY accessories for on-line air monitoring and canister analysis

UNITY 2 thermal desorber with 3-channel Air Server

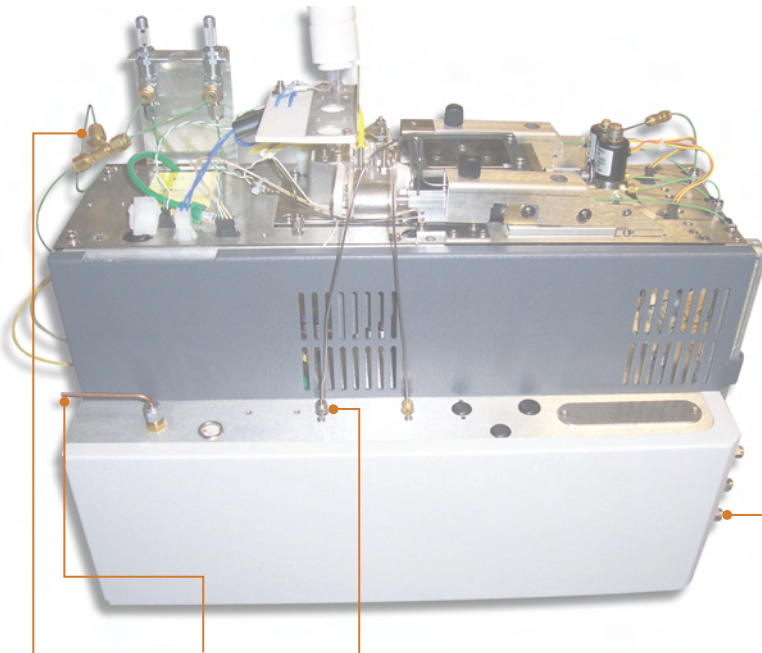

Ferrule,
 $\frac{1}{8}$ " \times $\frac{1}{16}$ "
U-FV003

Attach pump
 here, e.g.
U-ASPM1 or
U-ASPM2

Interface link tube assembly:
SERASU-5043 (series 2 Air Server 3/8)
SERASU-5021 (series 1 Air Server 3/8)

CIA 8



Filter, disk, sintered PTFE
 (inside sample ports)
U-DISK4

Sample transfer
 line
SERASU-5041
 (CIA 8)

Description	Part number
Ferrule, $\frac{1}{8}$ " \times $\frac{1}{16}$ ", graphite/Vespel, pk 10 (PEEK to $\frac{1}{8}$ " brass unions)	U-FV003
Tubing, PEEK, $\frac{1}{16}$ " o.d. \times 0.03" bore, 1 m	SERZ-0108
Split filter tube, glass, 3 $\frac{1}{2}$ ", packed with charcoal	SERAAA-1600
Tubing, PTFE, $\frac{1}{8}$ ", 1 m	SERZ-0062
Interface link tube assembly (series 1 Air Server 3/8)	SERASU-5021
Interface link tube assembly (series 2 Air Server 3/8)	SERASU-5043
Sample transfer line (ASIS 8 and CIA 8 only)	SERASU-5041
Pump, 115 V, for unpressurised samples	U-ASPM1
Pump, 230 V, for unpressurised samples	U-ASPM2
Ferrule, $\frac{1}{8}$ " \times $\frac{1}{8}$ ", Vespel (used on UNITY copper vents)	U-FV004
Filter, disk, sintered PTFE, 3.2 mm section, pk 10	U-DISK4

Description	Part number
Dryer kit for series 2 Air Server and CIA systems	U-ASDRY
Dryer kit for series 1 Air Server 3/8	U-ASDRY-1S
Connection kit, to connect series 1 Air Server 3/8 (or CIA 8) and ULTRA (50:50) to the same UNITY 1	U-UASK2
Connection kit, to connect series 2 Air Server 3/8 and ULTRA 2 to the same UNITY 2, 3 $\frac{1}{2}$ "	U-UASK2-2S
Connection kit, to connect series 2 Air Server 3/8 and ULTRA 2 to the same UNITY 2, 4 $\frac{1}{2}$ "	U-UASK2-XZ



For more information on any of Markes International's products, download the brochures from Markes' website.

CIA Advantage™

Cryogen-free autosampler for analysing air in canisters or bags

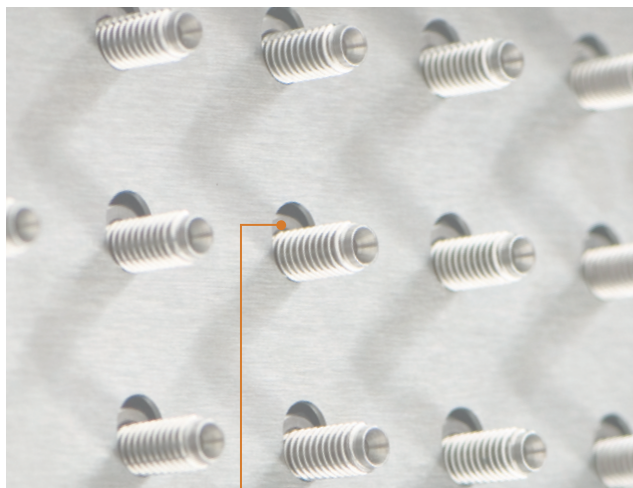

Filter, disk, sintered PTFE
(inside sample ports)
U-DISK4

Description	Part number
Dryer kit for CIA Advantage systems	U-ASDRY
Humidifier, for humidification of purge gas	U-HUMID
Heated sample lines (14 lines, each 1.8 m length)	U-HTLNKT
Filter, disk, sintered PTFE, 3.2 mm section, pk 10	U-DISK4
Pump, 115 V, for unpressurised samples	U-ASPM1
Pump, 230 V, for unpressurised samples	U-ASPM2
Split filter tube, glass, 3½", packed with charcoal	SERAAA-1600
Sample loop, 0.1 mL	SERZ-0993
Sample loop, 0.5 mL	SERZ-0994
Sample loop, 1 mL	SERZ-0516
Sample loop, 2 mL	SERZ-0995

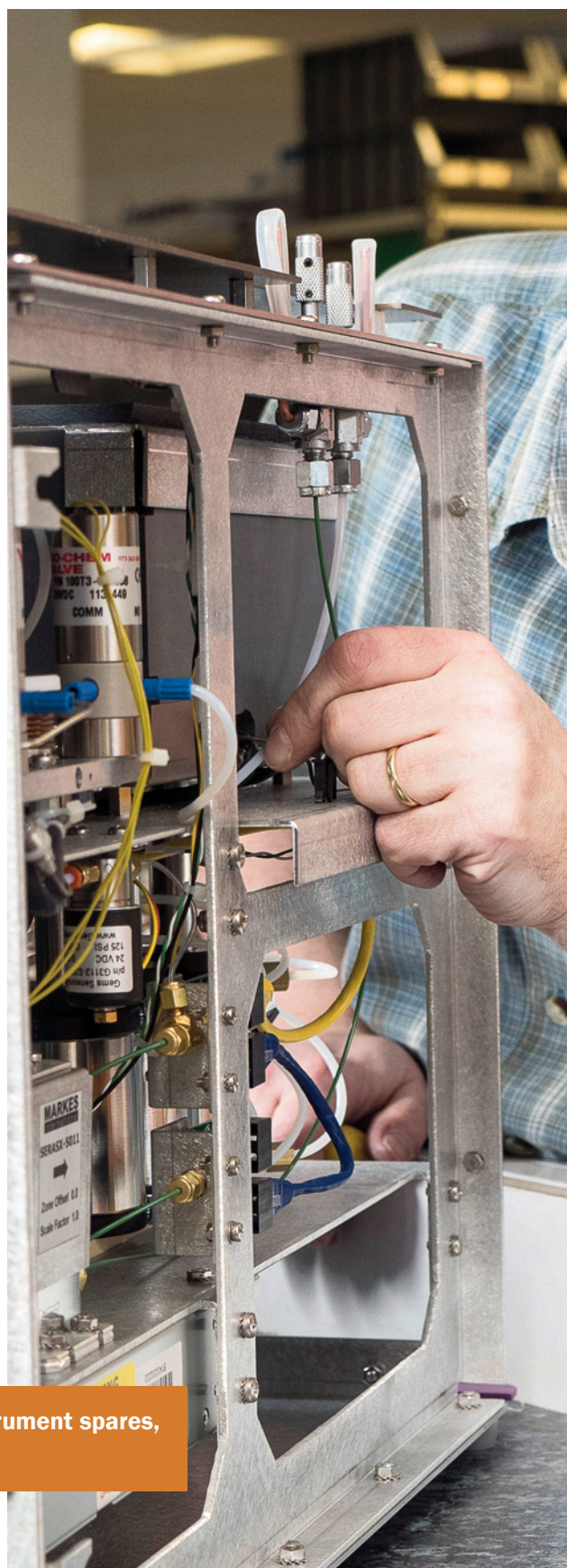

To order any of Markes International's instrument spares, simply telephone or send an email.

TT24-7™

Twin-trap thermal desorption system for continuous near-real-time monitoring

TT24-7 Series 1

In June 2013, TT24-7 Series 1 was discontinued. However, key accessories and consumables are still available from Markes International, as listed on this page.

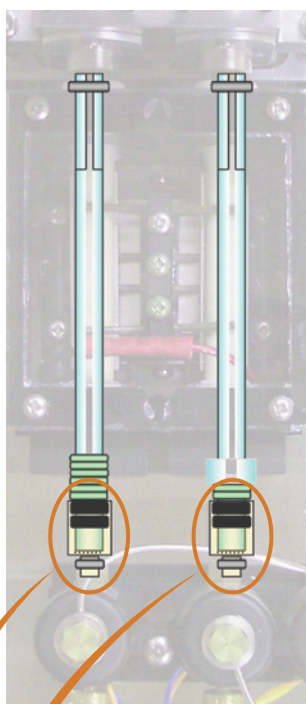

Key components in the TT24-7 Series 1 twin-trap assembly

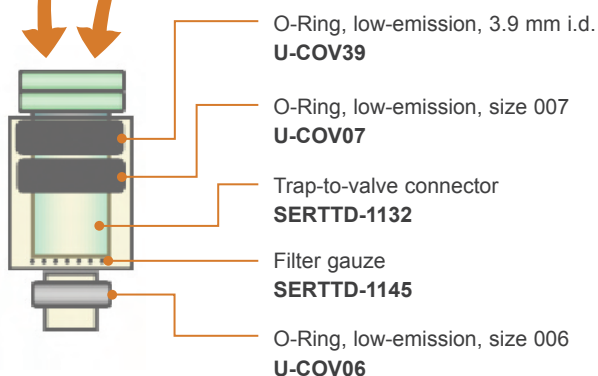

General (see adjacent diagram)

Description	Part number
O-Ring, low-emission, size 006, pk 10	U-COV06
O-Ring, low-emission, size 007, pk 10	U-COV07
O-Ring, low-emission, size 010, pk 10	U-COV10
O-Ring, low-emission, 3.9 mm i.d., pk 10	U-COV39
Filter, disk, sintered PTFE, 5.1 mm section, pk 10	U-DISK1
Filter, disk, sintered PTFE, 6.5 mm section, pk 10	U-DISK3
Gauze filter, flexible link	SERTTD-1145
Gauze filter, 1/4", inert, sample inlet, TT24-7	SERTTD-1150
Fused silica transfer line insert (0.25 mm i.d.) and PTFE sleeve	SERUTD-5093
Split filter tube, stainless steel, 3/2", packed with charcoal	SERUTD-5065
Ferrule, 1/16" x 0.4 mm graphite/Vespel, pk 10 (connects fused silica transfer line)	U-FV001
Trap-to-valve connector	SERTTD-1132

Miscellaneous

Description	Part number
Recycle power box for TT24-7 (assists remote operation)	U-RCYBX
Pump, 115 V, for unpressurised samples	U-ASPM1
Pump, 230 V, for unpressurised samples	U-ASPM2
Dual regulator pneumatics accessory (for dry gas and carrier gas regulation)	U-GAS01



To order any of Markes International's instrument spares, simply telephone or send an email.

TT24-7 Series 2

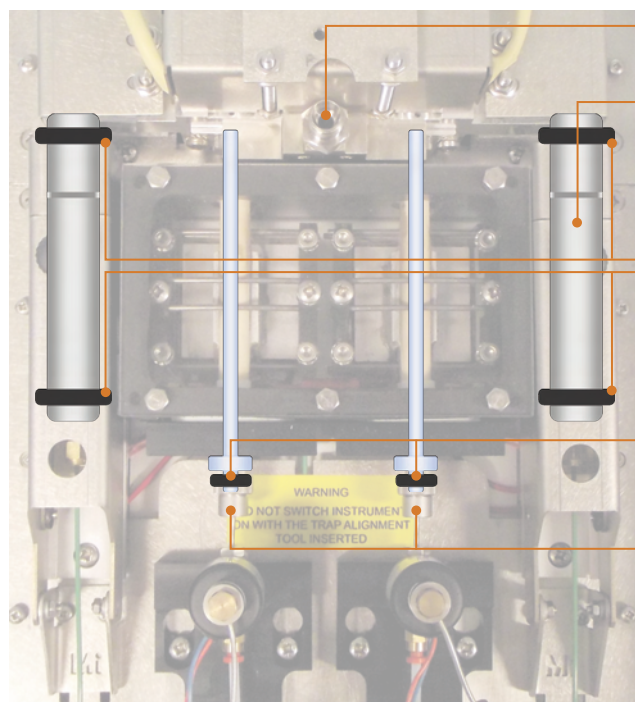

- Gauze filter, 1/4", inert, sample inlet, TT24-7
SERTTD-1150
- Split filter tube, stainless steel, 3 1/2", packed with charcoal
SERUTD-5065
- O-Ring, low-emission, size 010
U-COV10
- O-Ring, low-emission, size 007
U-COV07
- Cup mesh for cold trap link, 6 mm
SERAAA-1603

General (see above diagram)

Description	Part number
O-Ring, low-emission, size 007, pk 10	U-COV07
O-Ring, low-emission, size 010, pk 10	U-COV10
Filter, disk, sintered PTFE, 5.1 mm section, pk 10	U-DISK1
Filter, carbon, TT24-7 Series 2 air inlet	U-FLTRTT-C
Cup mesh for cold trap link, 6 mm	SERAAA-1603
Gauze filter, 1/4", inert, sample inlet, TT24-7	SERTTD-1150
Fused silica transfer line insert (0.25 mm i.d.) and PTFE sleeve	SERUTD-5093
Split filter tube, stainless steel, 3 1/2", packed with charcoal	SERUTD-5065
Split filter tube, glass, 4 1/2", packed with charcoal	SERAAA-5167
Ferrule, 1/16" x 0.4 mm graphite/Vespel, pk 10 (connects fused silica transfer line)	U-FV001
Quick-seal column connector, pk 10	C-QSC10

Miscellaneous

Description	Part number
Dryer kit for series 2 Air Server and CIA systems	U-ASDRY
Heated sample line, inert, 2 m	U-HSLTT
Mass flow controller (MFC), digital, 2–500 mL/min	U-DMFC-2S
UNITY 2 tube oven conversion kit, 3 1/2" to 4 1/2" (user-installable)	U-35TO45KT
Pump, 115 V, for unpressurised samples	U-ASPM1
Pump, 230 V, for unpressurised samples	U-ASPM2
Dual regulator pneumatics accessory (for dry gas and carrier gas regulation)	U-GAS01

For more information on any of Markes International's products, download the brochures from Markes' website.

UNITY™ 1

First-generation cryogen-free manual thermal desorber

In February 2008, UNITY 1 was discontinued. However, key accessories and consumables are still available from Markes International, as listed on these pages.

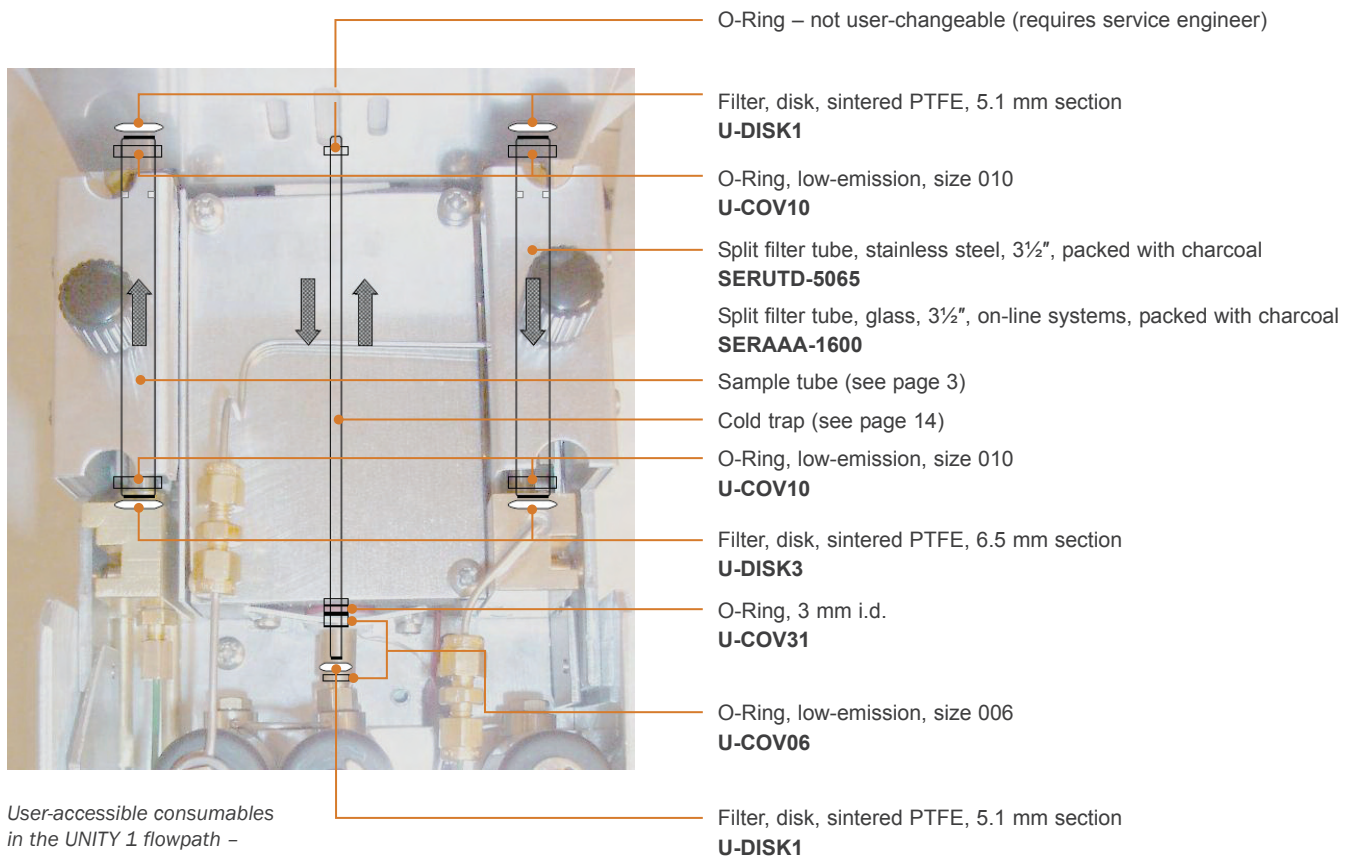

User-accessible consumables in the UNITY 1 flowpath – please see next page for full spares listing.



For information on spares for UNITY 1 and upgrade options, please talk to Markes International's product specialists.



General (see diagram on previous page)

Description	Part number
O-Ring, low-emission, size 006, pk 10	U-COV06
O-Ring, low-emission, size 010, pk 10	U-COV10
O-Ring, low-emission, size 010, pk 100	U-COV100
O-Ring, 3 mm i.d., pk 10	U-COV31
Fused silica transfer line insert (0.25 mm i.d.) and PTFE sleeve	SERUTD-5093
Split filter tube, stainless steel, 3½", packed with charcoal	SERUTD-5065
Split filter tube, glass, 3½", packed with charcoal (used for on-line systems)	SERAAA-1600
Fuse, 5 mm × 20 mm, 6.3 A, antisurge	SERZ-FS6A3
Ferrule, 1/16" × 0.4 mm graphite/Vespel, pk 10 (connects fused silica transfer line)	U-FV001
Ferrule, 1/16" × 1/16" graphite/Vespel, pk 10 (PEEK connections/bypass line)	U-FV002
Ferrule, 1/8" × 1/16" graphite/Vespel, pk 10 (PEEK connections/bulkhead unions)	U-FV003
Filter, disk, sintered PTFE, 5.1 mm section, pk 10	U-DISK1
Filter, disk, sintered PTFE, 6.5 mm section, pk 10	U-DISK3
Quick-seal column connector, pk 10 (connects fused silica to column)	C-QSC10

Tools and installation connections

Description	Part number
O-Ring insertion tool	SERZ-0285
O-Ring extraction tool	SERZ-0351
O-Ring service kit, 3½" tubes only (includes U-COV10, U-DISK1, SERZ-0285, SERZ-0351)	U-ORKIT
Tube extractor tool	SERUTD-5062
Trap alignment tool	SERUTD-5064
Standard tool kit	SERUTD-5063
UNITY-to-GC transfer line clamp (for use as spacer inside GC oven)	SERUTD-1125
Washer, ¼" × 1", for use with SERUTD-1125	SERZ-0371
Washer, ¼" × 1½", for use with SERUTD-1125	SERZ-0372
Nut, ¼"-20 UNC, stainless steel, for end of transfer line (for UNITY 1 from U-10284)	SERZ-NU14SS
Nut, M6, stainless steel, for end of transfer line (for UNITY 1 prior to U-10284)	SERZ-NM6FSS

Cables

Description	Part number
Cable assembly, lead, null modem (PC to TD communications cable)	SERZ-0189
Cable assembly, PCB GC interface and cable, standard	SERUTD-5095
Cable assembly, PCB GC interface and cable, Agilent	SERUTD-5098
Cable assembly, PCB GC interface and cable, Thermo	SERUTD-5108
Cable assembly, PCB GC interface and cable, Varian/Bruker	SERUTD-5116

Miscellaneous

Description	Part number
UNITY to UNITYe conversion kit (converts UNITY 1 from manual to electronic carrier control)	SERUTD-5103
Universal Direct Inlet Accessory, 3½"	U-INLET



Routine maintenance kits

Routine maintenance kits contain sufficient spares (O-rings, PTFE filters, etc.) for approximately 12 months' use. Where indicated, the relevant cold trap is included.

Suggested maintenance schedules

Suggested maintenance frequencies are given below. However, in some cases (depending on the application), items may need replacing more often.

UNITY 1 and 2

Condition/change charcoal filter (split tube)	3 months ¹
Replace/repack cold trap	12 months ¹
Replace fused silica transfer line	12 months
Change sample tube O-rings/filters	12 months, or if damaged/leaking
Cold trap seals	12 months, or if damaged/leaking

TD-100

Condition/change charcoal filter (split tube)	3 months ¹
Replace/repack cold trap	12 months ¹
Replace fused silica transfer line	12 months
Change sample tube O-rings/filters	12 months, or if damaged/leaking
Cold trap seals	12 months, or if damaged/leaking
Replace O-rings in DiffLok caps	If damaged/leaking
Change nozzle seals	If damaged/leaking

ULTRA

Replace O-rings in DiffLok caps	If damaged/leaking
Change nozzle seals	If damaged/leaking

Air Server, CIA 8 and CIA Advantage

Replace filter disks	12 months
----------------------	-----------

1. Note that these parts may require changing more frequently in automated systems.

Description	Part number
Routine maintenance kit, UNITY 1, specify cold trap	RMK-0001
Routine maintenance kit, UNITY 1, without cold trap	RMK-0004
Routine maintenance kit (ECC), UNITY 1, contains U-T11GPC cold trap	RMK-012
Routine maintenance kit, UNITY 2, 3½", specify cold trap	RMK-0001-2S
Routine maintenance kit, UNITY 2, 3½", without cold trap	RMK-0004-2S
Routine maintenance kit (ECC), UNITY 2, 3½", with U-T11GPC-2S cold trap	RMK-012-2S
Routine maintenance kit, UNITY 2, 4½", specify cold trap	RMK-0001-XZ
Routine maintenance kit, UNITY 2, 4½", without cold trap	RMK-0004-XZ
Routine maintenance kit, TD-100, specify cold trap	RMK-0009
Routine maintenance kit, TD-100, without cold trap	RMK-0010
Routine maintenance kit for TT24-7, without cold traps	RMK-0005
Routine maintenance kit, 3½", Air Servers and CIA systems	RMK-0003-2S

i As well as routine maintenance procedures carried out by the user, Markes International's specialists strongly recommend that a routine maintenance service is carried out on your TD system, by a trained service engineer, at least once a year.





Laboratory accessories

A comprehensive range of accessories
for your laboratory

Product highlights

- Pneumatic control accessories specifically for Markes International's instruments
- Leak detectors, flowmeters and gas purifiers for quality assurance of gas flows
- Range of precision syringes for gas and liquid injections
- Consumables for capillary columns



**Contact Markes
International for
expert advice**

Email

enquiries@markes.com

Web

www.markes.com

Telephone

UK: +44 (0)1443 230935

USA: 866-483-5684 (toll-free)

Germany: +49 (0)6102 8825569

Pneumatic control accessories

Dual regulator pneumatics accessory

Markes International's high-quality dual regulator pneumatics accessory controls both carrier gas and dry gas flows, and is strongly recommended for all Markes' thermal desorbers.

It consists of a stainless steel regulator (0–60 psig) for control of the carrier gas, and a standard regulator (0–100 psig) for control of the dry gas. Both lines also have on/off toggle valves.



Description	Part number
Dual regulator pneumatics accessory (for dry gas and carrier gas regulation)	U-GAS01

Single regulator pneumatics accessory

The single regulator pneumatics accessory is recommended for:

- Controlling the purge gas supply on ULTRA and TD-100 autosamplers with internal standard functionality.
- Regulating the pressure of internal standard (IS) gas if no other appropriate regulation is supplied.
- Controlling the supply gas to the Micro-Chamber/Thermal Extractor or TC-20.

It consists of a high-quality (stainless steel) regulator (0–60 psig) and an on/off toggle valve.

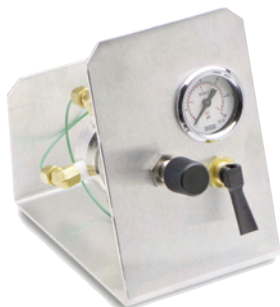

Description	Part number
Single regulator pneumatics accessory (for carrier gas regulation)	U-GAS03

Helium leak detector

This portable, highly sensitive helium leak detector for TD–GC systems provides the accurate, sensitive and rapid detection of carrier gas leaks that is essential for TD–GC troubleshooting.

Gas leaks are clearly indicated on the LED display, and it is powered by rechargeable batteries for ease of portability.

Full specifications for the helium leak detector can be found on Markes International's website.



Description	Part number
Helium leak detector including 230 V charger	C-HEL23
Helium leak detector including 115 V charger	C-HEL11

Flowmeter

With resolution of 0.1 mL/min, and accuracy typically better than $\pm 2.5\%$, this solid-state digital flowmeter offers outstanding performance for measuring TD gas.

It is compatible with eight gases: air, argon, argon–5% methane, carbon dioxide, helium, hydrogen, nitrogen and oxygen, in the range 0.1–500 mL/min.

Calibration is traceable to the UK National Physical Laboratory (NPL) standards, and an annual recalibration service (for helium, air and nitrogen) is offered on a return-to-factory basis.

Full specifications for the flowmeter can be found on Markes International's website.



Description	Part number
Digital flowmeter	C-FLMTR
Recalibration service for digital flowmeter (return to Markes)	C-FLCAL

Gas purifiers

Markes International's specialists strongly recommend these carrier gas purifiers to avoid contamination of the analytical system with hydrocarbons, oxygen or water. General-purpose purifiers are available for standard TD-GC operation, as well as high-capacity purifiers for specialised applications.

Hydrocarbon trap

The hydrocarbon trap is ideal for the removal of C₃+ hydrocarbons in helium, hydrogen, nitrogen, argon-methane and air. Refill kits are also available. The trap has a maximum flow capacity of 2 L/min and the stated life is 16 cylinders.¹

Water vapour trap

This molecular sieve trap efficiently removes water from helium, hydrogen, nitrogen, air, etc. The trap has a maximum flow capacity of 2 L/min and the stated life is 68 cylinders.¹

Oxygen/water trap

This trap reduces O₂ levels to less than 2 ppb.² It can extract contaminating oxygen at 10 ppm from at least three 8.5 m³ cylinders, and the maximum flow capacity is 250 mL/min.

Helium purifier

This purifier removes O₂, H₂O, hydrocarbons, CO₂ and CO from helium, giving an output gas that is 99.99999% pure. The maximum flow capacity is 8 L/min, and the stated life is 13 standard cylinders² of 99.999% helium.

High-capacity gas purifier

This specialised gas purifier removes both O₂ and H₂O from any common carrier gas (except hydrogen) by a catalytic reaction. It can purify up to 60 tanks of heavily contaminated gas containing 100 ppm O₂ and/or H₂O at flow rates of up to 1.1 L/min. A pressure gauge should be fitted at the outlet to monitor the pressure drop across the purifier – when the drop exceeds 10 psi the purifier tube should be replaced.

1. Based on standard 218 ft³ cylinder containing 50 ppm contaminants.
2. When the level in the incoming gas does not exceed 10 ppm.

Description	Part number
Gas purifier, hydrocarbon trap, 120 cc, 1/8" fittings	C-HCTRP
Gas purifier, hydrocarbon trap, refill material	C-RFHT
Gas purifier, water vapour trap, 200 cc, 1/8" fittings	C-MSTRP
Gas purifier, water vapour trap, refill material	C-RFMST
Gas purifier, oxygen/water trap, 120 cc, 1/8" fittings	C-O2TRP
Gas purifier, helium purifier, 1/8" fittings	C-HEPUR
Gas purifier, high-capacity, 230 V, 1/8" fittings	C-HCP23
Gas purifier, high-capacity, 110 V, 1/8" fittings	C-HCP11
Gas purifier, high-capacity, replacement purifier tube, 1/8" fittings	C-HCPTB
Gas purifier, high-capacity, replacement element, 230 V	C-HCE23
Gas purifier, high-capacity, replacement element, 110 V	C-HCE11
Gas purifier, high-capacity, outlet pressure gauge	C-HCPPG



To order any of Markes International's laboratory accessories, simply telephone or send an email.

Syringes

Markes International offers a selection of precision syringes, for both liquid and gas injections.

The **1 µL plunger-in-needle liquid syringe** fitted with a repeating adaptor provides $\pm 2\%$ accuracy and reproducibility for injection volumes down to 0.1 µL.

The **5 µL plunger-in-barrel liquid syringe** provides $\pm 1\%$ accuracy and reproducibility for injection volumes between 1 and 5 µL.

The **50 mL and 100 mL gas syringes** with removeable Luer locks provide $\pm 1\%$ accuracy and reproducibility for injection volumes down to 10 mL. The maximum gas temperature is 120°C.

Description	Part number
Syringe, 1 µL, plunger-in-needle with repeating adaptor, 50 mm needle length, 0.63 mm needle o.d.	C-SYL00-1UL
Syringe, 1 µL, replacement needle and plunger repair kit	C-SYLRP-1UL
Syringe, 5 µL, plunger-in-barrel fixed needle, 50 mm needle length, 0.47 mm needle o.d.	C-SYL00-5UL
Syringe, 50 mL, gas-tight, removable Luer lock	C-SYG00-50ML
Syringe, 50 mL, gas-tight, replacement plunger	C-SYGPL-50ML
Syringe, 50 mL, gas-tight, replacement Luer lock needles, 50 mm needle length, 0.63 mm needle o.d., pk 5	C-SYGND-50ML
Syringe, 100 mL, gas-tight, removeable Luer lock	C-SYG00-100ML
Syringe, 100 mL, gas-tight, replacement plunger	C-SYGPL-100ML
Syringe, 50 mL, gas-tight, replacement Luer lock needles, 50 mm needle length, 0.63 mm needle o.d., pk 5	C-SYGND-100ML

Capillary column cutting tool

Used to cut the ends of fused silica tubing (e.g. transfer line insert or capillary columns) to ensure burr-free square ends, and reliable capillary–capillary connections.

Description	Part number
Fused silica column-cutting tool	C-FSCCT

Fused silica column connectors

Single-use quick-seal **capillary column connectors** are supplied with every Markes International TD system, and are used to connect the fused silica transfer line insert to the GC capillary column inside the GC oven. They are suitable for most routine applications.



Reusable nut-and-ferrule **SilTite™ mini-unions** are recommended to make capillary–capillary connections for TD–GC systems incorporating an MS detector.



Description	Part number
Quick-seal column connector, pk 10	C-QSC10
SilTite mini-union, connects 0.25 mm fused silica transfer line to capillary column (up to 0.25 mm i.d.)	C-MU000
Ferrules, SilTite mini-union, 0.1–0.25 mm i.d. (columns up to 0.25 mm i.d.), pk 10	C-MUF25
Ferrules, SilTite mini-union, 0.32 mm i.d. (0.32 mm i.d. columns), pk 10	C-MUF32

Copper tubing and unions

This solvent-washed refrigeration-grade $\frac{1}{8}$ " copper tubing should be used to supply gases to TD–GC systems. It should not be brazed, and should only be connected using GC-compatible Swage-type unions.



Description	Part number
Copper tubing, 3 m	C-CUTUB-3M
Union, brass, $\frac{1}{8}$ ", T-shaped	SERZ-0104
Union, brass, $\frac{1}{8}$ "– $\frac{1}{8}$ "	SERZ-0026



To order any of Markes International's laboratory accessories, simply telephone or send an email.

Sorbents

Bulk sorbents from Markes – opening up a range of tube packing options

Product highlights

- Bulk sorbents for tube packing
- Popular Tenax® sorbents for routine applications
- Graphitised carbon blacks for trace-level applications
- Carbonised molecular sieves for highly volatile compounds
- Quartz and glass wools for very high-boiling and highly reactive compounds



**Contact Markes
International for
expert advice**

Email

enquiries@markes.com

Web

www.markes.com

Telephone

UK: +44 (0)1443 230935

USA: 866-483-5684 (toll-free)

Germany: +49 (0)6102 8825569

Porous polymers

Most porous polymer sorbents are inert, making them suitable for the analysis of labile and reactive compounds such as thiols and CS gas. In addition, their broadly hydrophobic nature allows them to be used for sampling in humid conditions.



Description	Part number
Sorbent, Tenax TA (35/60), 10 g	C-TNXTA
Sorbent, Tenax TA (60/80), 10 g	C-TNXTA60
Sorbent, Tenax GR (35/60), 10 g	C-TNXGR
Sorbent, Tenax GR (60/80), 10 g	C-TNXGR60
Sorbent, PoraPak N (50/80), 20 g	C-2PPKN
Sorbent, PoraPak Q (50/80), 20 g	C-2PPKQ
Sorbent, HayeSep D (60/80), 20 g	C-2HSPD

Graphitised carbon blacks

These are non-specific carbon sorbents, widely used for trace-level applications due to their minimal artefact levels. They vary from very weak to medium/strong, and are used for a wide range of VOCs and SVOCs.



Description	Part number
Sorbent, Carbograph 2TD (20/40), 10 g	C-CG220
Sorbent, Carbograph 2TD (40/60), 10 g	C-CG240
Sorbent, Carbograph 2TD (60/80), 10 g	C-CG260
Sorbent, Carbograph 1TD (20/40), 10 g	C-CG120
Sorbent, Carbograph 1TD (40/60), 10 g	C-CG140
Sorbent, Carbograph 1TD (60/80), 10 g	C-CG160
Sorbent, Carbograph 4TD (20/40), 10 g	C-CG420
Sorbent, Carbograph 5TD (20/40), 10 g	C-CG520
Sorbent, Carbograph 5TD (40/60), 10 g	C-CG540



For more information on particular sorbent characteristics, analyte ranges and advice on successful use, download Application Note 005.

Carbonised molecular sieves

Carbonised molecular sieves are the strongest sorbents and are used to trap the most volatile compounds.



Description	Part number
Sorbent, Carboxen 569 (60/80), 10 g	C-C569
Sorbent, SulfiCarb (40/70), 10 g	C-SLCRB
Sorbent, Carbosieve SIII (60/80), 10 g	C-CSIII
Sorbent, Carboxen 1003 (40/60), 10 g	C-C1000
Sorbent, Carboxen 1000 (60/80), 10 g	C-C1003

Zeolite molecular sieves

These are very selective hydrophilic sorbents used for specific TD applications.



Description	Part number
Sorbent, molecular sieve 5 Å, 20 g	C-MSV5A
Sorbent, molecular sieve 13X, 20 g	C-MS13X

Other sorbents

Other materials, such as quartz beads, quartz wool and glass wool, can be used in sorbent tubes and cold traps.



Description	Part number
Quartz beads, 1.5 mm, pk 100	C-QTZBD
Quartz wool, 10 g	C-QUTZW
Glass wool, silanised, 10 g	C-SILGW
Glass wool, unsilanised, 10 g	C-UNSGW
Sorbent, activated charcoal, 5 g	C-CHARC



Confused about any aspect of sorbent selection or tube packing? Contact Markes International for expert advice.

Get your application questions answered – call our experts or visit www.markes.com



Contact Markes International for expert advice

Email

enquiries@markes.com

Web

www.markes.com

Telephone

UK: +44 (0)1443 230935

USA: 866-483-5684 (toll-free)

Germany: +49 (0)6102 8825569

Applications Guides

Four comprehensive and clearly illustrated TD Applications Guides are available **FREE** from Markes. Each one contains 20–50 pages of representative applications across the following areas:

I. Environmental Monitoring & Exposure to Chemicals at Work

Covering:

- Industrial emissions – stack tests, fence line monitoring and vapour intrusion.
- Detection of VOCs in air – whether urban or rural, workplace or residential.
- Assessment of personal exposure – by diffusive (passive) monitoring or breath testing.

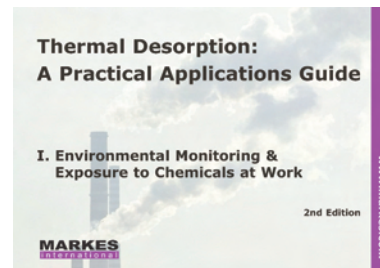

II. Residual Volatiles & Material Emissions Testing

Covering:

- VOC emissions – from construction products and other materials.
- VOC content – of raw materials and consumer products.
- Residual compounds – in polymers, food packaging, and pharmaceuticals.

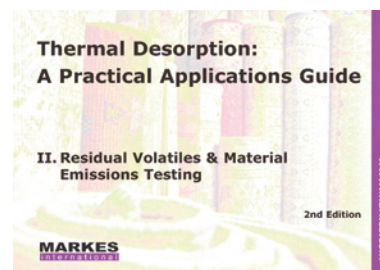

III. Defence and Forensic

Covering:

- Detection of chemical warfare agents – continuous near-real-time monitoring of military/civilian facilities, studies of permeation through protective material.
- Forensic analysis – drugs of abuse, arson residues, explosive vapours, shotgun propellant, inks, paper and paint.

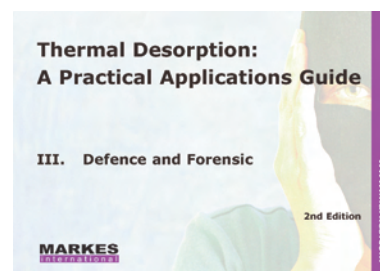

IV. Food, Flavour, Fragrance & Odour Profiling

Covering:

- VOC characterisation of foods and beverages.
- Detection of off-odours or contaminants.
- Fragrance/odour profiling of consumer products.

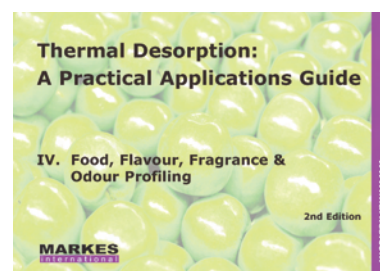

Email Markes International today to request your free copy of any of these Applications Guides.



Visit www.markes.com to discover the range of over 100 Application Notes on all of these areas and more.

List of part numbers

Where a component appears as part of a kit, a letter 'K' appears after the page number.

C0-AXXX-0000	4, 41, 44K, 46K	C3-EXXX-5266	8	C-DF100E	22	C-KITSP-2S	38, 47
C0-BXXX-0000	41, 47K	C-10LOK	17	C-DFS20	22	C-LFP-01	20
C0-CXXX-0000	6, 41	C-2HSPD	66	C-DL010	16, 53	C-MNCANSL	24
C0-FXXX-0000	41	C-2PPKN	66	C-DL010-XZ	53	C-MNCANSS	24
C0-LXXX-0000	9	C-2PPKQ	66	C-DL100	16, 53	C-MS13X	67
C0-NXXX-0000	7, 41, 46K	C-325FS	22	C-DL100-XZ	53	C-MSTRP	63
C1-AAXX-5003	4, 44K, 45K	C-AC020	16	C-DL160	48K	C-MSV5A	67
C1-AAXX-5009	4, 45K	C-AC200	16	C-DL1P0	16, 53	C-MU000	64
C1-AAXX-5020	4	C-ASK1168SL	24	C-DL1P0-XZ	53	C-MUF25	64
C1-AAXX-5342	4	C-ASK1168SS	24, 45K	C-DL1S0	16, 53	C-MUF32	64
C1-ACAX-5009	4, 5	C-ASK2USS	24, 45K	C-DL1S0-XZ	53	C-O2TRP	63
C1-AXXX-5003	4	C-ASK2UST	24	C-DLP10	16, 53	C-PI010	41, 46K
C1-AXXX-5009	4	C-ASKMNSL	24	C-DLP10-XZ	53	C-PI100	41
C1-AXXX-5020	4	C-ASKMNSS	24	C-DLP80-XZ	48K	C-PL010	41, 44K, 46K
C1-AXXX-5342	4	C-B100M	40	C-DLS10	16, 53	C-PL100	41
C1-BAXX-5039	7	C-BCR	10	C-DLS10-XZ	53	C-QSC10	44K, 46K, 50, 52, 57, 59, 64
C1-BAXX-5072	28	C-BIO01	40	C-EPA3251-SS2	4	C-QTZBD	67
C1-BXXX-5039	7	C-BIO10	40	C-EZVOCAK	20	C-QUTZW	44K, 46K, 47K, 67
C1-BXXX-5072	28	C-BIO100	40	C-EZVOCKT	20, 47	C-RFHCT	63
C1-CAXX-5003	6, 46K, 48K	C-BIO50	40	C-EZVOCPO	20, 44K, 45K, 47K	C-RFMST	63
C1-CAXX-5342	6	C-BTX100-10	31, 45K	C-FLCAL	62	C-SCRIBE	11, 47K
C1-CXXX-5003	6	C-BTX1UG-10	31	C-FLMTR	62	C-SILGW	67
C1-CXXX-5342	6	C-C1000	67	C-FP020	16, 44K, 46K	C-SLCAN1	24
C1-DAXX-5003	8	C-C1003	67	C-FP020-XZ	16	C-SLCAN6	24
C1-DXXX-5003	8	C-C569	67	C-FP200	16	C-SLCRB	67
C1-EAXX-5003	8	C-CF010	16	C-FP200-XZ	16	C-SOILG-SS1	4
C1-EAXX-5312	8	C-CF010-XZ	16	C-FSCCT	64	C-SOILG-SS2	4
C1-EXXX-5003	8	C-CF020	16, 47K	C-GS14A-1PPM	32	C-SP010	17, 44K
C1-EXXX-5312	8	C-CF020-XZ	16	C-GS15-1PPM	33	C-SP100	17
C1-LXXX-7001	9	C-CF100	16	C-GSPAMS-EPA	33	C-SPTA	28
C1-LXXX-7003	9	C-CF100-XZ	16	C-GSREG-100	32, 33	C-SPTD1	38
C2-AAXX-5032	4, 44K	C-CF200	16	C-GSSUL-1PPM	32	C-SPTD10	38
C2-AAXX-5126	4	C-CF200-XZ	16	C-GSVOL-1PPM	32	C-SPTD10-6MM	38
C2-AAXX-5149	45K	C-CFA20	16	C-GTSP10	17, 46K, 47K	C-SPTD1-6MM	38
C2-AAXX-5270	4	C-CFA200	16	C-GZ020	17	C-SPTD5	38, 47K
C2-AAXX-5032	4	C-CG120	66	C-GZ200	17	C-SPTD5-6MM	38
C2-AXXX-5126	4	C-CG140	66	C-GZ2000	17	C-SYG00-100ML	64
C2-AXXX-5270	4	C-CG160	66	C-GZI10	17	C-SYG00-50ML	64
C2-BAXX-5201	7	C-CG220	66	C-GZI100	17	C-SYGND-100ML	64
C2-BAXX-5259	7, 45K	C-CG240	66	C-HCE11	63	C-SYGND-50ML	64
C2-BAXX-5267	7	C-CG260	66	C-HCE23	63	C-SYGPL-100ML	64
C2-BXXX-5201	7	C-CG420	66	C-HCP11	63	C-SYGPL-50ML	64
C2-BXXX-5259	7	C-CG520	66	C-HCPP23	63	C-SYL00-1UL	64
C2-BXXX-5267	7	C-CG540	66	C-HCPPPG	63	C-SYL00-5UL	64
C2-CAXX-5138	44K	C-CHARC	67	C-HCPTB	63	C-SYLRP-1UL	64
C2-CAXX-5250	44K	C-CHK10	29, 44K	C-HCTRP	63	C-T4GCF10	12
C2-CAXX-5314	6	C-CHK10-ME	29, 46K	C-HEL11	62	C-T4GCF100	12
C2-CXXX-5314	6	C-CL010	22, 44K, 45K	C-HEL23	62	C-T6GCF10	12
C3-AAXX-5266	4, 44K, 45K	C-CL100	22	C-HEPUR	63	C-T6GCF100	12
C3-AAXX-5304	4, 5, 46K	C-CPLOK	17, 44K, 45K, 46K, 48K	C-KIT012-2S	44	C-TAG10	12, 47K
C3-AXXX-5266	4	C-CSIII	67	C-KIT03-2S	44	C-TAG100	12
C3-AXXX-5304	4	C-CSLR	28	C-KITCW-2S	44	C-TAGG10	12
C3-BAXX-5267	7	C-CUST-10	31	C-KITDD-2S	41, 46	C-TAGG100	12
C3-BXXX-5267	7	C-CUST-20	31	C-KITEV01-2S	45	C-TAGKT	47
C3-CAXX-5304	6	C-CUST-40	31	C-KITEV02-2S	45	C-TAGKY	12
C3-CXXX-5304	6	C-CUTUB-3M	64	C-KITEV03-2S	45	C-TAGLOK	12, 47K
C3-DAXX-5266	8, 47K	C-CUTUB-3M	64	C-KITEV04-2S	45	C-TAGTL	12, 47K
C3-DXXX-5266	8	C-DF010	22, 44K, 45K	C-KITME01-2S	46	C-TBMTE	17
C3-EAXX-5266	8	C-DF010E	22	C-KITME02-2S	46		
		C-DF100	22				

C-TCF10	12	MTS-5010	21	SERUTE-5143	50, 52	U-GAS01	56, 57, 62
C-TCF100	12	MTS-5011	21	SERUTE-5144	50, 52	U-GAS03	37, 62
C-TCFP10	12, 47K	MTS-5013	21	SERZ-0022	32	U-HS5TD	39
C-TCFP100	12	M-TSTIN	37, 48K	SERZ-0026	64	U-HSKIT	39
C-TNXGR	66	P-0001	40	SERZ-0062	54	U-HSLTT	57
C-TNXGR60	66	P-00010	40	SERZ-0104	64	U-HSNAS	39
C-TNXTA	46K, 66	P-00020	40	SERZ-0108	54	U-HSTD-G1290	39
C-TNXTA60	66	P-00030	40	SERZ-0157	52	U-HSTD-G1888	39
C-TO17XX-10	31, 45K	P-00040	40	SERZ-0189	50, 52, 59	U-HSTD-HS40	39
C-TOCAN1	24, 45K	P-CP001	40	SERZ-0285	52, 59	U-HSV00	39
C-TOCAN6	24	P-CP010	40	SERZ-0351	52, 59	U-HSV00	39
C-TOCLN1L	25	P-CP020	40	SERZ-0371	52, 59	U-HSVCR	39
C-TOCLN3L	25	P-CPF10	40	SERZ-0372	52, 59	U-HSVDC	39
C-TOCLNMN	25	P-CPP10	40	SERZ-0516	55	U-HTLNKT	55
C-UNS10	18	P-CPS20	40	SERZ-0669	48K	U-HUMID	55
C-UNS100	18	P-CPU10	40	SERZ-0861	48K	U-INLET	39, 52, 59
C-UNSGW	67	P-FORMR	40	SERZ-0993	55	U-INLET-XZ	52
E-MACAR	42	R-FLTR4	39	SERZ-0994	55	U-ORKIT	52, 59
E-MACNT	42	RMK-0001	60	SERZ-0995	55	U-RACK02	25
E-MATBG5	42	RMK-0001-2S	60	SERZ-1070	20, 21	U-RCYBX	56
E-MATBV5	42	RMK-0001-XZ	60	SERZ-1076	20, 21	U-SW001-2S	52
E-MICAR	42	RMK-0003-2S	60	SERZ-1097	20, 21	U-T1HBL	14
E-MICAR10	42	RMK-0004	60	SERZ-FS6A3	59	U-T1HBL-2S	14
E-MICOR	42	RMK-0004-2S	60	SERZ-NM4FLGSS	48K	U-T2GPH	14
E-MITBE5	42	RMK-0004-XZ	60	SERZ-NM6FSS	59	U-T2GPH-2S	14
E-MITBE50	42	RMK-0005	60	SERZ-NU14SS	52, 59	U-T6SUL	14
M-CTE120I	36	RMK-0006	37, 48K	T-1VX	14	U-T6SUL-2S	14
M-CTE120TI	36	RMK-0006HT	37, 48K	T-2HD	14	U-T7EMP	14
M-CTE250I	36	RMK-0008	39	T-3GBGE	14	U-T7EMP-2S	14
M-CTE250TI	36	RMK-0009	60	T-4ATX	14	U-T8CUS	14
M-DSK15-120	37, 48K	RMK-0010	60	T-6EMP	14	U-T8CUS-2S	14
M-DSK15-250	37, 48K	RMK-012	60	T-7CUS	14	U-T9TNX-2S	47K
M-DSKPF	37	RMK-012-2S	60	T-8MAT	14	U-T10CW	14
M-HUMID-MCTE	37	R-TC20-1	39	T-9GPC	14	U-T10CW-2S	14, 44K
M-MC006	37	R-TC20-2	39	T-11OP	14	U-T11GPC	14
M-MCHOR	37	SERAAA-1600	52, 54, 55, 59	U-35TO45KT	52, 57	U-T11GPC-2S	14, 44K
M-MCHOR250	37	SERAAA-1603	57	U-45TO35KT	52	U-T12ME	14
M-MCHSI	36, 48K	SERAAA-5167	52, 57	U-ASDRY	54, 55, 57	U-T12ME-2S	14, 46K
M-MCHSS	36	SERASU-5021	54	U-ASDRY-1S	54	U-T15ATA	14
M-MCHSS250	36	SERASU-5041	54	U-ASPM1	39, 54, 55,	U-T15ATA-2S	14, 44K, 45K
M-MCHSS250I	36, 48K	SERASU-5043	54		56, 57	U-T16GHG	14
M-MCTOP	36	SERLFP-5002	20, 21	U-ASPM2	39, 54, 55,	U-T16GHG-2S	14
M-MCTOP250	36	SERLFP-5003	20, 21		56, 57	U-T17O3P	14
M-MCTOP250I	36, 48K	SERMTD-1213BU	50, 53	U-COV06	50, 52, 56, 59	U-T17O3P-2S	14
M-MCTOPI	36, 48K	SERMTD-1382	50, 53	U-COV07	48K, 50, 53,	U-T18325-2S	14
M-PRMIN1-250	37	SERMTD-1394BU	53		56, 57	U-TAGRW-2S	53
M-PRMIN-250	37	SERTTD-1132	56	U-COV10	48K, 50, 52,	U-TECHCD	52
M-PRMINSS1-250	37	SERTTD-1145	56		53, 56, 57, 59	U-TOCLN120	25
M-PRMINSS-250	37	SERTTD-1150	56, 57	U-COV100	50, 52, 53, 59	U-TOCLN220	25
M-PRO30-250	37	SERUTD-1125	52, 59	U-COV31	59	U-TRAY	50, 53
M-PRSPT-250	37	SERUTD-5062	52, 59	U-COV39	56	U-TRAY-XZ	53
M-SPC05-120	37, 48K	SERUTD-5063	52, 59	U-COV45	16, 48K, 52,	U-UASK2	54
M-SPC05-250	37, 48K	SERUTD-5064	52, 59		53	U-UASK2-2S	53, 54
M-SPC15-120	37, 48K	SERUTD-5065	50, 52, 56,	U-COV450	16	U-UASK2-XZ	53, 54
M-SPC15-250	37, 48K		57, 59	U-DISK1	50, 52, 56,	U-ULKIT	48
M-SPGSC-120	37, 48K	SERUTD-5093	50, 52, 56,		57, 59	U-ULKIT-XZ	48
M-SPGSC-250	37, 48K		57, 59	U-DISK3	56, 59	U-USKIT	53
M-STUKT250I	36, 48	SERUTD-5095	59	U-DISK4	54, 55	U-USKIT-2S	53
M-STUKTI	36, 48	SERUTD-5098	59	U-DMFC-2S	52, 57	U-USKIT-XZ	53
M-TCN04	37	SERUTD-5103	59	U-FLTRTT-C	57		
M-TCN06	37	SERUTD-5108	59	U-FV001	50, 52, 56,		
M-TCN64	37	SERUTD-5116	59		57, 59		
M-TICAP	37, 48K	SERUTE-5103	52	U-FV002	50, 52, 59		
MTS-32	21	SERUTE-5141	50, 52	U-FV003	50, 52, 54, 59		
MTS-5009	21	SERUTE-5142	50, 52	U-FV004	54		

Index

Where a component with a main entry is also mentioned elsewhere, the main entry is underlined.

Accessory pack, Easy-VOC	20	Carbosieve.....	67
Activated charcoal	67	Carboxen	67
ACTI-VOC.....	<u>20</u> , 21	Carrier, for macro connector.....	42
AIR proficiency testing scheme	30	Carrier, Tube.....	42
Air sampling kit, for canisters	24	Carrier gas purifiers.....	63
Air Server, spares	54	Cartridges, SPE-tD	38
Alignment tool, for cold traps	52, 59	Certified reference standard tubes	31
Alphanumeric etching, on sorbent tubes ...	10	Charcoal, activated.....	67
Aluminium diffusion caps	22	Chargers.....	20, 21
Aluminium storage caps	16	Check-standard tubes	29
Applications Guides.....	69	CIA 8, spares.....	54
AutoSecureTD interface kit.....	53	CIA <i>Advantage</i> , spares	55
Back-pressure adaptor, for ACTI-VOC	<u>20</u> , 21	Clamp, for transfer line	52, 59
Bag sampling accessory, for ACTI-VOC.....	<u>20</u> , 21	Clips, for personal monitoring	22
Banding, of sorbent tubes	10	Cold traps.....	14
Barcode reader, for sorbent tubes	10	Cold trap alignment tool	59
Barcoding, of sorbent tubes	10	Cold trap extraction tool, for TT24-7	14
Batteries.....	21	Collar spacers	37
Bio-VOC.....	40	Column connectors	50, 52, 57, 59, <u>64</u>
Blanking plugs, for VOC-Mole	40	Column cutting tool	64
Brackets, for TO-Clean.....	25	Conditioner/cleaner, for canisters	25
Brass storage caps.....	16	Conditioner, for tubes.....	39
Brass unions	64	Connection kits.....	39, 53, 54
Breath sampler	40	Connector, Macro	42
BTX standard tubes.....	31	Connector, trap-to-valve	56
Cables.....	21, 50, 52, 59	Conversion kit, tube oven	52, 57
Calibration	27	Conversion kit, UNITY to UNITYe	52, 59
Calibration Solution Loading Rig (CSLR).....	28	Copper tubing	64
Canisters	24	Crimper.....	39
Canister cleaner.....	25	Crimps	39
Canister rack.....	25	CRS tubes	31
Capillary column connectors	44, 46, 50, 52, 57, 59, <u>64</u>	CSLR (Calibration Solution Loading Rig).....	28
Capillary column cutting tool	64	Cup mesh for cold trap link	57
CapLok tool	<u>17</u> , 20	Cutting tool, for capillary columns.....	64
Caps, DiffLok.....	<u>16</u> , 53	DAAMS tubes	9
Caps, diffusion.....	22	Decapper.....	39
Caps, diffusion-locking.....	16	DiffLok caps	<u>16</u> , 53
Caps, push-on	16	Diffusion caps.....	22
Caps, storage	16	Diffusion-locking caps	16
Caps, storage, compatible with TubeTAG....	12	Diffusive sampling.....	22
Caps, tube interface, for Micro-Chamber/Thermal Extractor....	37	Direct desorption	41
Carbograph	66	DNPH cartridge accessories	37
Carbon blacks, graphitised.....	66	Dryer kits.....	54, 55, 57
Carbonised molecular sieves.....	67	Dry-purging equipment, for tubes	39
		Dual regulator pneumatics accessory	56, 57, <u>62</u>

Easy-VOC	20	Inserts for liquid samples, for Micro-Chamber/Thermal Extractor....	37
Empty sorbent tubes	4, 6, 7, 9	Instrumentation check-standard tubes	29
Equilibrium headspace sampling	39	Interface kit, AutoSecureTD	53
Etching, of sorbent tubes.....	10	Interface link, for Air Server.....	54
Evolved gas collection	42	Internal standards	32
External calibration.....	28, 32	Labels, for autosampler trays.....	50, 53
Extraction tool, for cold traps, for TT24-7 ...	14	Labelling, of sorbent tubes	10
Extraction tool, for tubes.....	52, 59	Lapel clips, for personal monitoring.....	22
Ferrules	16, 40, 50, 52, 54, 56, 57, 59, 64	Leak detector, helium.....	62
Field Station, for US EPA Method 325.....	22	Lids, for Micro-Chamber/Thermal Extractor..	36
Filter assembly, for ACTI-VOC.....	20, 21	Liners, for direct desorption	41
Filter, carbon	39, 57	Liquid syringes	64
Filter, disk.....	50, 52, 54, 55, 56, 57, 59	Low-flow pump.....	20, 21
Filter, frit	24	µ-CTE (Micro-Chamber/Thermal Extractor)..	36
Filter, gauze.....	56, 57	MacroTubes.....	42
Flowmeter.....	62	Mains adaptors/chargers	21
Focusing traps	14	Maintenance kit, for HS5-TD	39
Formaldehyde sampling accessories.....	37	Maintenance kit, for Micro-Chamber/Thermal Extractor....	37
Fuse	59	Maintenance kits, for other instruments....	60
Fused silica column connectors.....	64	Mass flow controllers (MFCs)	52, 57
Fused silica column-cutting tool.....	64	Material emissions check-standard tubes ..	29
Fused silica transfer line insert	50, 52, 56, 57, 59	Maxi Rack.....	25
Gas pneumatic controllers.....	62	Mesh, cup, for cold trap link.....	57
Gas purifiers	63	Micro-Chamber/Thermal Extractor.....	36
Gas standards.....	32	Microthermal analysis	42
Gas syringes.....	64	MicroTubes.....	42
Gauzes, sorbent-retaining.....	17	Miniature air-sampling canisters.....	24
Glass calibration tubes	28	Mini-unions.....	64
Glass direct desorption tubes	7	Molecular sieves, carbonised	67
Glass sorbent tubes	7	Molecular sieves, zeolite.....	67
Glass wool	67	Mouthpieces, for Bio-VOC	40
Grab-sampler	20	MTS-32 (multiple tube sampler)	21
Graphitised carbon blacks.....	66	Multi-tube conditioner	39
HayeSep	66	Needle assembly, for HS5-TD	39
Headspace-thermal desorption.....	39	Nuts	52, 59
Heated sample lines	55, 57	Ordering information	2
Helium leak detector	62	O-Rings	16, 37, 40, 42, 50, 52, 53, 56, 57, 59
Helium purifier	63	O-Ring insertion/extraction tools	50, 52, 53, 59
High-capacity gas purifier	63	O-Ring service kit.....	52, 59
HS5-TD (headspace-thermal desorber).....	39	Oxygen/water trap	63
HS-TD (headspace-thermal desorption)....	39	Ozone precursor/PAMS gas standard.....	33
Humidifier, for CIA Advantage.....	55	Passive sampling.....	22
Humidifier, for Micro-Chamber/Thermal Extractor....	37	PEEK tubing	54
Hydrocarbon trap.....	63	Penclips.....	22
Impact former, for VOC-Mole.....	40	Permeation accessory, for Micro-Chamber/Thermal Extractor....	37
Inert-coated stainless steel sorbent tubes..	6	Personal monitoring sorbent-tube clips.....	22

Pneumatics accessories	37, 56, 57, <u>62</u>	Sorbent tubes, sampling arrow	10
PoraPak	66	Sorbent tubes,	
Porous polymers	66	unpacking/repacking service.....	13
Power recycle box	56	Sorptive extraction cartridges.....	38
Power supplies.....	21	Spacers,	
Proficiency testing	30	for Micro-Chamber/Thermal Extractor....	37
PTFE discs/inserts,		Spares, for TD instruments.....	49
for Micro-Chamber/Thermal Extractor....	37	SPE-tD cartridges.....	38
PTFE liners, for direct desorption	41	Split filter tubes	50, 52, 54, 55,
PTFE tubing	54		56, 57, 59
Pumped sampling.....	20	Springs	17
Pumps	20, 21, 39, 54,	Sprung spacers,	
	55, 56, 57	for Micro-Chamber/Thermal Extractor....	37
Push-on caps	16	Stainless steel sorbent tubes.....	4
Quartz beads	67	Stainless steel tubing.....	32
Quartz wool	67	Standards.....	27
Quick-seal column connector	50, 52, 57, 59,	Starter kit, Advanced TD	44
	<u>64</u>	Starter kits, application-specific.....	44
Rack, for canisters.....	25	Starter kits, Automated TD	48
Recalibration service, for flowmeter	63	Starter kit, Basic environmental.....	45
Recycle power box, for TT24-7.....	56	Starter kit, Basic material emissions.....	46
Regulator, for supplying standards	32, 33	Starter kit, Basic TD	44
RFID tags, for sorbent tubes.....	11, <u>12</u>	Starter kit,	
Routine maintenance kit, for HS5-TD	39	Comprehensive material emissions	46
Routine maintenance kit,		Starter kit, CWA.....	44
for Micro-Chamber/Thermal Extractor....	37	Starter kit, Diffusive monitoring	45
Routine maintenance kits,		Starter kit, Direct desorption	41, <u>46</u>
for other instruments.....	60	Starter kit, Easy-VOC	47
SafeLok tubes.....	8	Starter kits, general TD	44
Sample lines, heated	55, 57	Starter kit, HS5-TD.....	39
Sample loops, for CIA <i>Advantage</i>	55	Starter kits,	
Sample pans,		Micro-Chamber/Thermal Extractor	48
for Micro-Chamber/Thermal Extractor....	36	Starter kit, SPE-tD.....	38, <u>47</u>
Sampling arrow, on sorbent tubes	10	Starter kit, TO-15	45
Seals, Dowty, for VOC-Mole.....	40	Starter kit, TO-17	45
Septa	28, 37	Starter kit, TubeTAG.....	47
Serial numbers, on sorbent tubes	10	Storage caps, diffusion-locking	16
SilcoCan	24	Storage caps, long-term	16
SilTite mini-unions	64	Storage caps, short-term	16
Single regulator pneumatics accessory.....	62	SulfiCarb.....	67
Software, CD for UNITY 2.....	52	Sulfur component gas standard.....	32
Soil probe	40	Surface emissions accessories,	
Sorbents.....	65	for Micro-Chamber/Thermal Extractor....	37
Sorbent tubes	3	Syringes.....	64
Sorbent tubes, application-specific.....	5, 6, 7, 8	TAGLok tool	12
Sorbent tubes, banding of	10	TAG ^{SCRIBE}	11
Sorbent tubes, barcoding of	10	TC-20	39
Sorbent tubes, bespoke solutions	13	TD-100, spares	50
Sorbent tubes, conditioning of	13	Technical manual, for series 2 TD systems..	52
Sorbent tubes, labelling of.....	10	Tenax	66

Thermogravimetric analysis (TGA).....	42	Tubes, sorbent	3
Time-weighted-average sampling	24	TubeTAG.....	11
TO-15/TO-17 gas standard	33	TubeTAG accessories.....	12
TO-17 standard tubes.....	31	TubeTAG read/write option, for ULTRA 2	53
TO-Can	24	Tube tracking	11
TO-Clean	25	Tubing, copper	64
Tool kit, standard.....	52, 59	Tubing, PEEK.....	54
Transfer line	54	Tubing, PTFE.....	54
Transfer line clamp.....	52, 59	Tubing, stainless steel.....	32
Transfer line insert	50, 52, 56, 57, 59	TWA monitoring kit	24
Trap alignment tool.....	52, 59	U-INLET	39, 52, 59
Trap-to-valve connector	56	ULTRA 2, spares.....	53
Tray assemblies	50, 52	ULTRA-X, spares.....	53
TT24-7, spares.....	56	Unions, for connecting sorbent tubes.....	18
Tube adaptor assembly, for ACTI-VOC	20, 21	Unions, for copper tubing.....	64
Tubes, certified reference standard.....	31	Unions, for VOC-Mole.....	40
Tubes, check-standard	29	UNITY 1, spares	58
Tube conditioner.....	39	UNITY 2, spares	51
Tube connection unions.....	18	UNITY to UNITYe conversion kit.....	52, 59
Tubes, for direct desorption.....	7	Universal Direct Inlet Accessory	39, 52, 59
Tubes, external calibration.....	28	Vials, crimp-top	39
Tube extractor tool.....	52, 59	VOC-Mole.....	40
Tube labelling.....	10	Volatiles (Japan) component gas standard	32
TubeMate tool	17	Washers.....	52, 59
Tube oven conversion kit	52, 57	Water vapour trap.....	63
		Zeolite molecular sieves	67

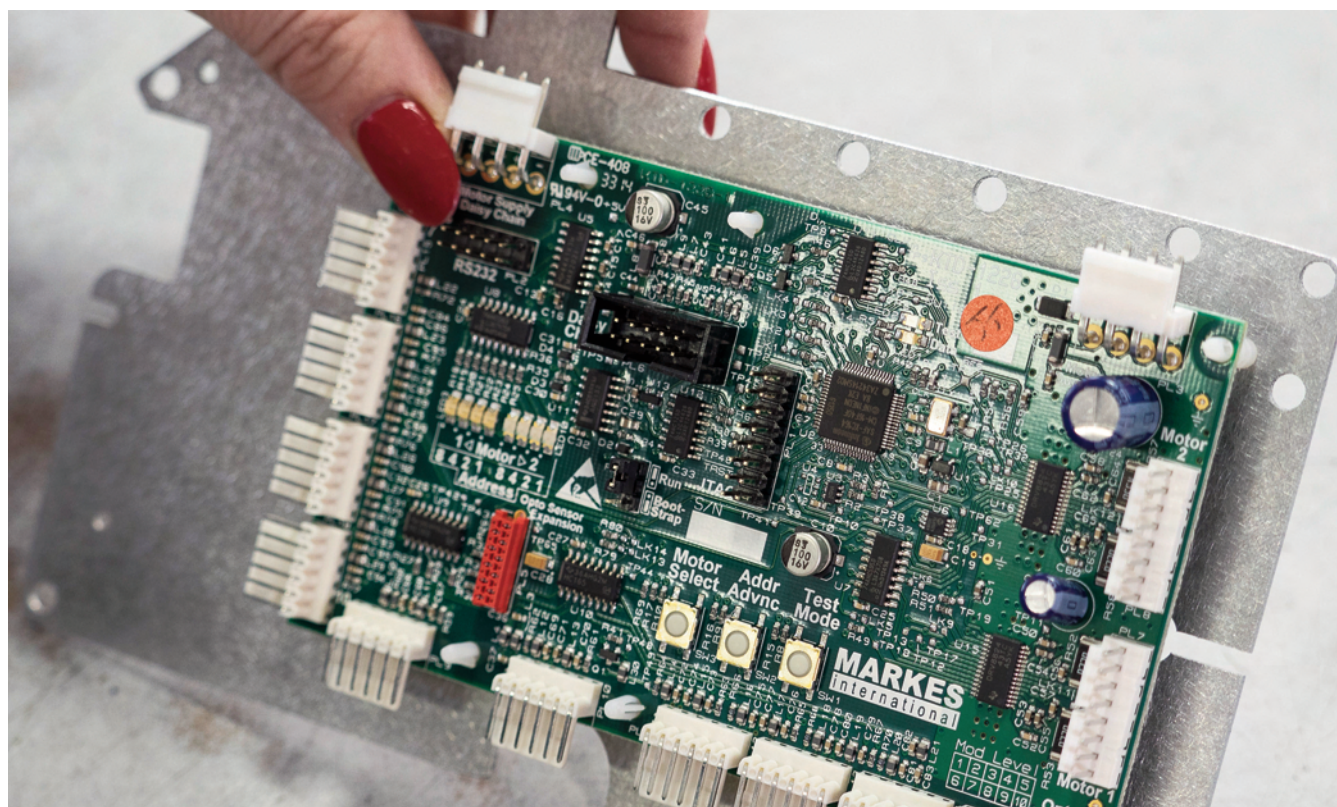

Trademarks

ACTI-VOC™, Air Server™, Bio-VOC™, CapLok™, CIA Advantage™, CSLR™, DiffLok™, Easy-VOC™, 325 Field Station™, HS5-TD™, MacroTube™, Micro-Chamber/Thermal Extractor™ (μ-CTE™), MicroTube™, MTS-32™, SafeLok™, SPE-tD™, SulfiCarb™, TC-20™, TD-100™, TT24-7™, TubeMate™, TubeTAG™, ULTRA™, UNITY™ and VOC-Mole™ are trademarks of Markes International.

Carboglyph™ is a trademark of LARA s.r.l., Italy.

Carbopack™ is a trademark of Supelco Inc., USA.

Carbosieve™ is a trademark of Supelco Inc., USA.

Carboxen™ is a trademark of Supelco Inc., USA.

ChemStation® is a registered trademark of Agilent Technologies Inc., USA.

Freon® is a registered trademark of E. I. du Pont de Nemours and Company, USA.

Gerstel® is a registered trademark of Gerstel GmbH & Co. KG., Germany.

HayeSep® is a registered trademark of Hayes Separations Inc., USA.

PoraPak™ is a trademark of Waters Associates Inc., USA.

SilcoCan® is a registered trademark of Restek, USA.

Siltek® is a registered trademark of Restek, USA.

SilTite™ is a trademark of SGE Analytical Science Pty Ltd, Australia.

Tenax® is a registered trademark of Buchem B.V., The Netherlands.

TO-Can® is a trademark of Restek, USA.

Twister® is a registered trademark of Gerstel GmbH & Co. KG., Germany.

Vespel® is a registered trademark of E. I. du Pont de Nemours and Company, USA.

Windows® is a registered trademark of Microsoft Corporation, USA.



Markes International

Since 1997, Markes International has been at the forefront of innovation for enhancing the measurement of trace-level volatiles by gas chromatography.

Markes' range of thermal desorption products, led by our flagship **UNITY™** and **TD-100™** thermal desorbers, have for well over a decade set the benchmark in the field for quality and reliability. Our comprehensive portfolio of thermal desorption products also includes numerous sampling accessories, and the widest range of consumables on the market.

In addition to our long-established reputation for thermal desorption, we also manufacture the **BenchTOF™** range of time-of-flight mass spectrometers for GC and associated software. Now featuring our unique **Select-eV®** variable-energy ion-source technology and **TOF-DS™** software, our BenchTOF range exemplifies our approach to our entire business – developing solutions from the ground up that allow our customers to meet analytical challenges with confidence.

Our factory, technical centre and headquarters is near Cardiff, UK, with laboratory and demonstration facilities in Cincinnati, Ohio, USA, and near Frankfurt, Germany. In 2013 we became a company of the Schauenburg International Group.



Markes International's facilities in the UK, Germany and USA (clockwise from top left).

About the Schauenburg International Group

The Schauenburg International Group is a family-owned technology business with more than 30 sites worldwide, and a focus on electronic technologies, machinery and equipment, plastics processing, and engineering products.

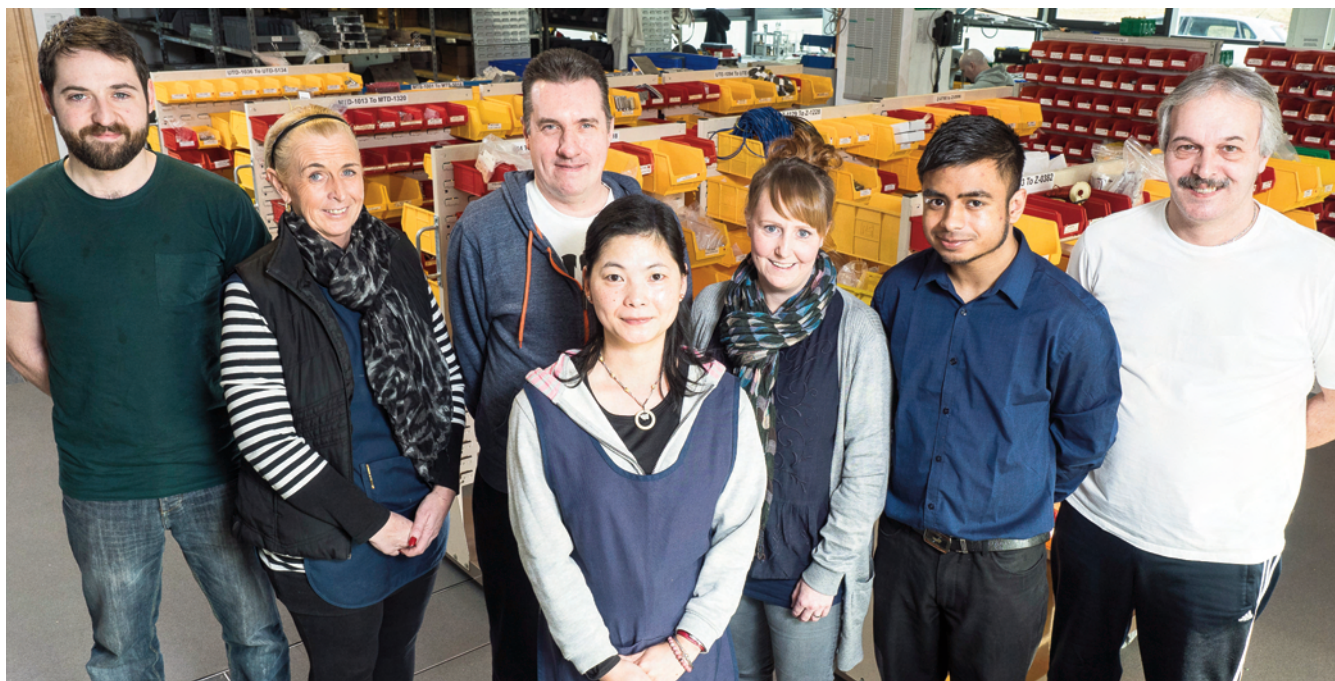

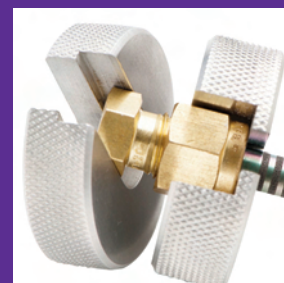

Markes International Ltd

Gwaun Elai Medi-Science Campus
Llantrisant
RCT, CF72 8XL
UK

T: +44 (0)1443 230935
F: +44 (0)1443 231531
E: enquiries@markes.com
W: www.markes.com

Markes International, Inc.

11126-D Kenwood Road
Cincinnati
OH, 45242
USA

T: 866-483-5684 (toll-free)
F: 513-745-0741
E: enquiries@markes.com
W: www.markes.com

Markes International GmbH

Schleussnerstrasse 42
D-63263 Neu-Isenburg
Frankfurt
Germany

T: +49 (0)6102 8825569
F: +49 (0)6102 8825583
E: enquiries@markes.com
W: www.markes.com

